



Brushless Screwdrivers for automated assembly machines

# **BLF-2000 / BLF-5000 / BLF-7000 / BLF-7000X / BLF-7025X**

Suction (Vacuum) Attachment

## **BLFQ Series / BLFR Series**

### **Operation Manual**

(June 2026)



## Table of Contents

- 03 Important Safety Instructions**
- 04 Introduction**
- 04 Features**
- 05 Cautions After Introducing the Screwdriver and the Power Supply**
- 05 Cautions When Installing the Screwdriver**
- 06 Cautions when using a universal joint**
- 07 Precautions**
- 08 About device adjustment**
  - Bit Attachment
  - About torque adjustment
- 10 Names of main components of the screwdrivers**
  - About flange
  - Combination table between the screwdrivers for automatic operation and the power supplies for them
- 11 Specifications of the screwdrivers**
  - Output torque guide (HI)
- 12 Exterior dimensions and details of the screwdrivers**
  - Figure of installation dimensions
- 14 Suction (Vacuum) Attachment BLFQ series**
  - BLFQ accessories list
  - Mouthpiece
  - Adjustment of mouthpiece
  - Bits
  - Checking Supplied Accessories
  - Assemble the Attachments
  - Replace the Torque Adjustment Spring (BLFQ-5000 Only)
- 17 Suction (Vacuum) Attachment BLFR series**
  - BLFR accessories list (Table 1)
  - Identification of the BLFR Mouthpiece Order Code
  - Types of spring loaded mouthpiece (attachable to BLFR-5000 and BLFR-7000 series)
  - Adaptive screw size indications (Table 2)
- 23 Exterior dimensions of the suction attachments**
- 25 Vacuum Pump VP-3**

### Abbreviations of product names

Product names are abbreviated as follows for convenience in this document, except for the cover page:

- Brushless Screwdrivers for automated assembly machines: screwdriver
- Power supply dedicated for Brushless Screwdriver for automated assembly machines: power supply
- BLF-7000, BLF-7000X and BLF-7025X models: BLF-7000 series

## Important Safety Instructions

Please read this manual and the power supply unit manual carefully before use to ensure proper operation. In addition, do not use the product in the way not described in this manual. Please note that we are not responsible for any problems caused by using the product in a manner that does not conform to the contents of this manual, using it improperly, or repairing / modifying by a third party except by us or someone specified by us.

### Wear appropriate clothes for safety

- To prevent being caught in the machinery, do not wear clothes with flapping cuffs, gloves or a tie.
- Wear protective eyeglasses and a safety hat if required.
- If you have long hair, tie it up to prevent from being entangled with the machine.

### Prepare an environment for safe work

- An electric leakage breaker and safety breaker should be installed for the commercial power supply.
- Do not allow any unauthorized persons to enter the work site. The site is especially dangerous for children.
- Use the screwdriver in a room of moderate temperatures and controlled humidity.
- Do not operate the screwdriver with wet or oily hands.
- Pay attention to lighting in the work site to make the workplace bright. However, avoid direct sunlight on the screwdriver.
- Always keep the work site tidy to create an environment to work easily.
- Working in an unnatural posture may be dangerous. Prepare a solid footing to keep your body stable while working.

### Avoid working near dangerous objects

- Never place inflammables such as gasoline, gas or adhesive and objects that may explode near the work site.

### Use specified power source

- Use only specified HIOS Controller.
- Never use more screwdrivers simultaneously than a controllable number.

### Hold the plug when you plug in/unplug the power cord

- When you plug in/unplug the power cord for the screwdriver, always hold the plug (do not pull the cord directly).
- Do not drag the cords. Also, do not allow the cords to touch hot objects, oil, sharp edges, etc.
- Do not apply excessive weight or pressure on the cord.

### Avoid places with water, moisture or oil

- Never use the screwdriver where there is a lot of dust, dirt, oil, corrosive gas, etc. Especially, if you use it in a place with high humidity, it may cause an electric shock or a malfunction. So, never use it in such a place.

### Stop using it when anything abnormal is detected

- If you notice anything abnormal in use such as uneven rotations, strange noises, overheating, shutdown by the breaker, etc., stop using the screwdriver immediately and ask for it to be repaired.

\* However, the screwdriver may become hot depending on work frequency, unusual kinds of screws, or other reasons. To avoid inconvenience on such an occasion and to extend the tact time, you should have a spare screwdriver or review if you have selected an appropriate one for the work.

- Avoid an overload which cannot be clutched out. Such overload may cause a failure of the motor.

### Keep hands away during rotation

- Never touch the rotating part of the screwdriver with your hands.
- If you wear gloves, it may become dangerous because gloves can be caught in the rotating bit. Avoid wearing gloves.

### Do not attach/remove the bit forcibly

- If you cannot attach/detach the bit even though you are following the instruction, please contact our customer HIOS distributor.

### Turn off the power supply when it is not in use

- Turn off the power supply and unplug when it is not in use.

### Notes for storage

- Store the screwdriver where it is at normal temperature and avoid a place with moisture and dust.
- Avoid an unstable place for storage. The screwdriver may fall.
- Keep the screwdriver out of reach of unauthorized persons including children.
- Make sure to remove the bit.
- When you don't use the screwdriver for a long time, remove the accessories and keep them in the packing box.

### Other notes

- Strong shocks or excessive force during setting or in use may cause malfunctions.
- Avoid unnecessary continuous rotation of the screwdriver by presetting appropriate overtime against the time required for screw tightening.
- Make sure to keep a spare screwdriver in case of an unexpected incident.



## Introduction

Thank you for purchasing the BLF series, BLFQ series or BLFR series of the brushless screwdrivers for automatic operation.

Before using, please make sure to read this instruction manual well and use the tools properly. Please keep this manual in a safe place after reading.

### NOTE

The screwdrivers have warranted its ability within controlled torque range.

However, please consider the following situation when installing the tools in customer's operation.

\* If there is any inclusion (ex. Universal joint) at joint part between screwdriver and bit, output torque would be badly affected by some conditions (ex. inertia or resistance). Please select proper model considering torque with a margin.

## Features

- Our brushless screwdrivers are durable and enable stable screw fastening.
- The durability has been improved by simplifying the control circuits.
- There are two types of the vacuum pick up screwdrivers.
  - The BLFQ is a standard vacuum pick up screwdriver.
  - The BLFR is for deeply recessed screws.

## Cautions After Introducing the Screwdriver and the Power Supply

### Rotation speed of the screwdriver

- The rotation speed is different for forward and reverse rotations. Please refer to the values on the specification of the screwdriver and the torque guide table only as rough guidelines.
- The rotation speed is measured without load. Please note the rotation speed varies when the set value is 27 or more.

The controlled torque values are measured with the combination of a HIOS Torque Meter HP-100 and a Fidaptor\*. The values during your work are not always the same as the values in the table. Please refer to the values in the table only as rough guidelines.

\* For measuring torque with the screwdriver, use a fidaptor (accessory of HP-100), which reduces and absorbs the inertia generated at stoppage and has the ability to reproduce near-screw-fastening conditions to detect the torque when the clutch fires during rotation of the screwdriver. Also, please use a dedicated torque measuring instrument, HM Series, which can measure output torque of the screwdriver after it is installed.

## Cautions When Installing the Screwdriver

- If you want to install screwdriver facing up, please contact us.
- About the speed setting for screwdriver descending  
If the descending speed of the Z-axis is faster than the screw fastening speed, screw floating may occur due to overloaded tightening. Set the descending speed of the screwdriver appropriate for the screw fastening.
- Consider the stiffness against Z-axis including the installation board of the screwdriver.

### NOTE

- Please select Z-axis based on the following formula:

Screwdriver weight + Installation angle weight = Tightening reaction force

Make sure to install the screwdriver with the above condition satisfied. (Please contact us for details.)

- Please determine the thickness of the installation board tolerable with stiffness and reaction force.

Guideline for the installation board thickness

- BLF-2000/BLF-5000: 8 mm or more
- BLF-7000 Series: 10 mm or more

- If the screw fastening cycle is short and constant torque is always required when a tapping screw is fastened, it is necessary to check the required torque level by using an actual machine. In such case, feel free to contact us.
- If the torque is high, presume that the reactive force against the screwdriver is strong and the stiffness of the installation flange and Z-axis will impact on the screw fastening.
- Even if the above setting conditions are satisfied, overload may occur. In such case, review the installation conditions.
- The flange and the main body of the screwdriver are fixed with left-handed screws.
- For the load in the direction to the axis of the screwdriver (thrust direction), design using a damper mechanism.

\* Dampers with simple shock absorbers are available from HIOS. Consider using them if appropriate.

### Product Name: BLF Damper Unit

Part Number: BLF-DP (\*Installation board is not included.)

#### Thrust Load Specifications

Initial load 0mm: Approx. 21.4 N

Stroke 7mm: Approx. 80.4 N

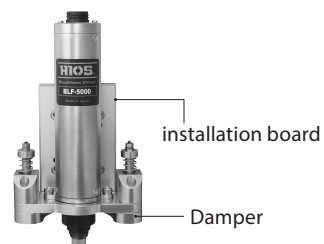

## Cautions when using a universal joint

- Offset from the center axis causes overload by twisting of the output axis. Incomplete fixation may cause power loss, overload on the screwdriver or twist, and may decrease the output power of the screwdriver.

As a result, incomplete tightening may occur even if the output torque is a standard value.

- When using a universal joint, make sure that a rotational load is not applied to the bit.

### ⚠ NOTE

When using a universal joint, output torque of the screwdriver and the actual output torque may be different due to inertia. Make sure to measure both torque of the screwdriver and the actual output torque.

- When a universal joint is installed, make sure not to overload in the direction of the axis of the screwdriver (thrust direction), and not to damage the workpiece and the screw bottom.

#### Guidelines for the load limit

**BLF-2000: 3kg or less**

**BLF-5000/BLF-7000 Series: 5kg or less**

- When a universal joint or fixture is installed under screw fastening conditions, implement test tightening several times.

1. Is it fastened at the set torque?
2. Is the rotating speed of the screwdriver constant?
3. Isn't the bit wobbling?
4. Is there any abnormal noise...etc? Check these prior to the final tightening.

- When using a universal joint, make sure the bit turns by hand.

#### <Example>

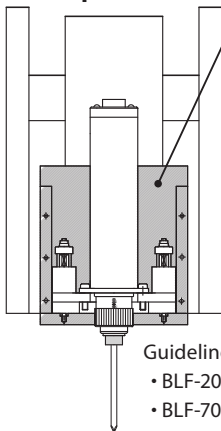

1. For the thickness of the installation board of the back board, appropriate thickness under the installation conditions should be kept when fixing.

Guidelines for the installation board thickness:

- BLF-2000 / BLF-5000: 8 mm or more
- BLF-7000 Series: 10 mm or more

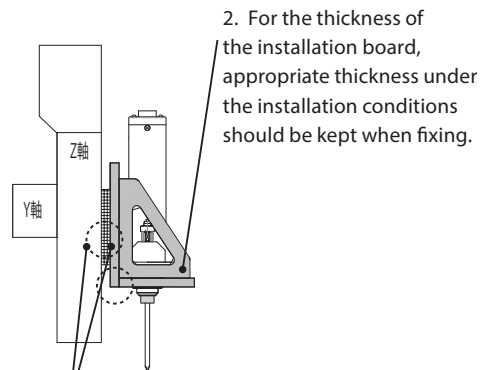

2. For the thickness of the installation board, appropriate thickness under the installation conditions should be kept when fixing.

3. When connecting an Angle to the Z-axis, fix it firmly. If it is loosely fixed, it may cause problems such as overload.

## Precautions

- Please read this instruction manual thoroughly before use to ensure proper operation.
- On any commercial power supply, install a ground-fault interrupt breaker and safety circuit breaker.
- Connect the power supply to ground and use only the rated voltage.
- Please consider every condition such as power loss and inertia due to the Joint Shaft part, etc. from the body to the bit of the screwdriver. Make sure to select the screwdriver that well meets the requirements.
- In case a universal joint or jigs are used, the actual output torque values may be different from the corresponding torque values displayed on the specification table.
- Please confirm that the screwdriver and the power supply are the right combination.
- The overload protection will be activated when the screwdriver is locked or has become overloaded. If the screwdriver is overloaded repeatedly, the maximum ratings of the power supply or screwdriver may be exceeded. If the screwdriver becomes overloaded during normal operation or begins to malfunction due to developing excessive heat, stop the ongoing operation immediately, turn the main power switch off, remove the power cable, and contact our service department or HIOS distributor for repairs.
- When fastening screws on workpieces constructed of plastics susceptible to static electricity build-up, operation should be done after static electricity has been discharged. If the work pieces that have not been properly discharged, static electricity may flow up through the end of the bit, causing malfunctions of the tools.
- Do not disassemble or modify the tools in any way, as doing so may cause malfunctions of the tools. Such malfunctions are not covered by the HIOS warranty and repairs may be refused.
- The operating environment for the screwdriver should be between 5°C and 40°C with relative humidity of 80% or less (there should be no possibility of condensation).
- Do not drop the tools or subject it to mechanical shocks.
- Always hold the plug when inserting or removing power cables or the driver cords into or from sockets.
- Do not drag cords or cables, subject them to oil or to sharp edges, or place them under heavy objects.
- If the tools will not be used for a long period of time, turn the main power switch OFF and unplug it from the service outlet.

# About device adjustment

## Bit Attachment

### 1 Bit attachment

- Bit attachment for BLF-2000 (Chart) -1  
Push in and hold the Joint Shaft Collar into the body of the screwdriver to insert the bit.
- Bit attachment for BLF-5000 / BLF-7000 Series (Chart)-2  
Pull up and hold the Joint Shaft Collar from the body of the screwdriver to insert the bit.

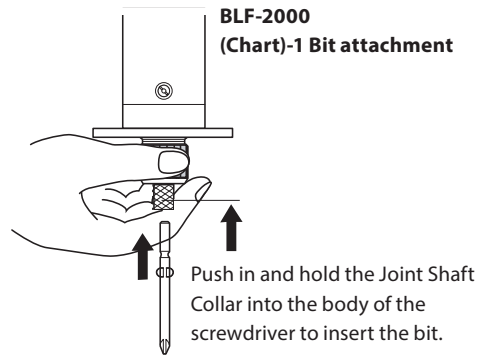

### 2 Please confirm the attached bit is locked firmly.

- BLF-2000 uses the bit of HIOS H4 (Ø4).
- BLF-5000 and BLF-7000 use the bits of HIOS H5 (Ø5).
- \* Please use HIOS genuine bits.

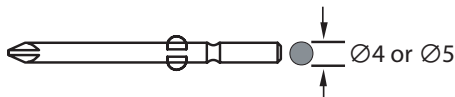

- The bit drive of BLF-7000X and BLF-7025X is 1/4 HEX. Please purchase the commercial products.

### BLF-5000 / BLF-7000 Series (Chart)-2 Bit attachment

- Pull up and hold the joint shaft collar from the body of the screwdriver to insert the bit.

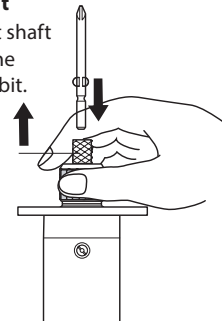

### CAUTION

Please purchase the commercial bit with the specified shape.

### Hex bit types that cannot be used

Hex bits with two recesses and double bits cannot be used with this product.

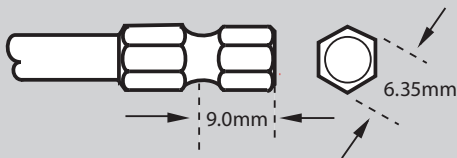

## About torque adjustment

- 1** In case the torque value of screw fastening is fixed in advance, refer to "Reference tables of output torques" and turn the Torque Adjustment nut on the screwdriver, using torque scale numbers (1-8) or (1-9).

### CAUTION

- Please use the reference tables of output torques as rough guideline to set torque.

- 2** Please rotate the torque control nut to reach the directly above position of the number.

#### Fixation method (BLF-2000 only)

BLF-2000 has a fixation mechanism with double lock nuts. The position set with the Fixing nut is the configured torque setting value.

- 2-1** Rotate the Fixing nut to reach the directly above position of the torque scale number on the screwdriver.

- 2-2** Rotate the Torque Adjustment nut to the position of the Fixing nut. Make sure to tighten the nut well then. To prevent position error of the Torque Adjustment nut, tighten the Fixing nut well while holding the Torque Adjustment nut.

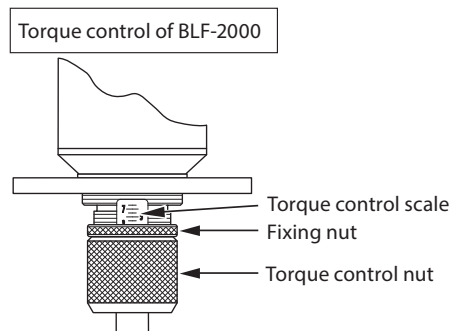

- 3** Turn on the tools and implement screw fastening. When it stops, check the screw and optimize the torque value.

\* To check the torque of the screwdriver.

- We recommend our Torque Meter: HM series. Even when you have only limited space, you can measure the torque of the screwdriver installed to the automated assembly equipment.

## Names of main components of the screwdrivers

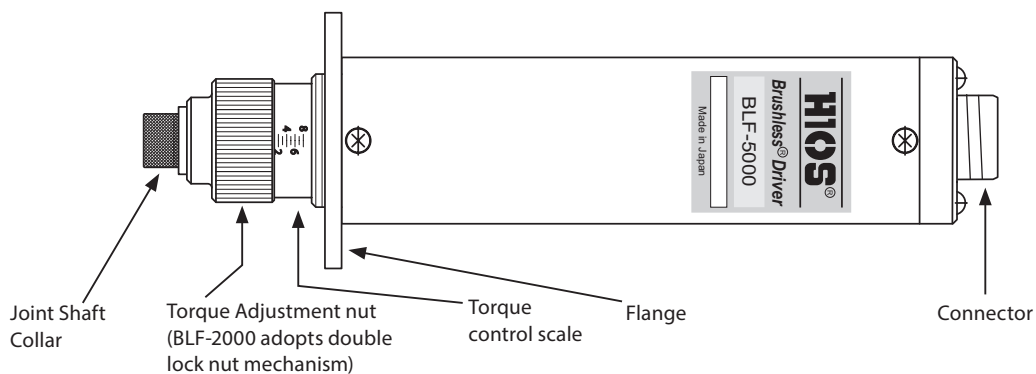

### About flange

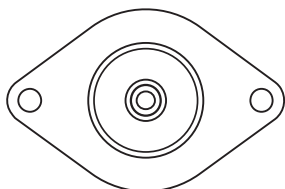

For BLF-2000

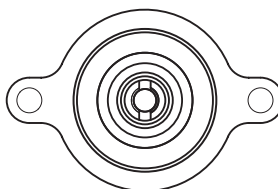

For BLF-5000 & 7000, 7000X, 7025X

### Combination table between the screwdrivers for automatic operation and the power supplies for them

Model	Convertible power supplies	Number of controllable screwdrivers
BLF-2000 BLF-5000	BLT-AY-61	1
BLF-7000 BLF-7000X BLF-7025X	BLT-AY-71	1

- For details of the power supply, please refer to the "Operation Manual" attached to the power supply for automatic operation.

## Specifications of the screwdrivers

Model	BLF series	BLF-2000	BLF-5000	BLF-7000	BLF-7000X	BLF-7025X
	BLFQ series	BLFQ-2000	BLFQ-5000	BLFQ-7000	-	-
	BLFR series	-	BLFR-5000	-	BLFR-7000X	BLFR-7025X
Controlled Torque Range	N·m	0.03–0.35	0.3–1 (BLFQ spring for low torque 0.2-0.5)	0.7–2	0.7–2	1.2–2.5
	lbf·in	0.26–3.0	2.6–8.8	6–17	6–17	9–22
Torque Switching		Stepless adjustment				
Unloaded Rotation Speed (r.p.m) ±10% 11 steps switching	LOW rotation 05 - 15	120–345	115–320	150–450	150–450	120–350
	HI rotation 20 - 30	690–975	660–940	495–735	495–735	400–600
Available screws (mm)	Machine screw	1.0–2.3	2.0–3.0	3.0–4.0	3.0–4.0	3.0–4.0
	Tapping screw	1.0–2.0	2.0–2.6	3.0–4.0	3.0–4.0	3.0–4.0
Bit Drive*1	BLF series	H4 (Ø4)	H5 and 5HEX (both can be used)	H5 (Ø5)	1/4HEX	1/4HEX
	BLFQ series				-	-
	BLFR series	-	Ø4(screw type)	-	Ø4(screw type)	Ø4(screw type)
Weight (g)*2	BLF series	315	470	700	700	700
	BLFQ series	390	560	830	-	-
	BLFR series	-	700	-	1,070	1,070
Included Accessories	Driver cord	Length: 3m (10P), Weight: 320g, Order Code: BLF7-0612-VI				
	Spring	Silver	Adjustment spring for low torque (BLFQ-5000 Only)	-	-	-

\*1: Bit drive "1/4" is HEX 6.35mm, 5HEX is HEX 5mm.

\*2: The weight (g) does not include the driver cord.

● The suction (vacuum attachment) for BLFR-7025X is available as a custom-made item. Please feel free to ask us.

### CAUTION

● The controlled torque range of BLF-7000 series may be different from the value in the table according to the working conditions.

### Output torque guide (HI)

N·m **BLF-2000\***

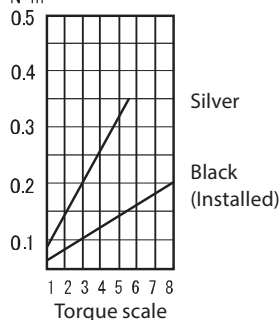

N·m **BLF-5000**

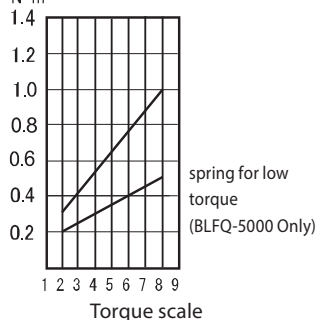

N·m **BLF-7000 series**

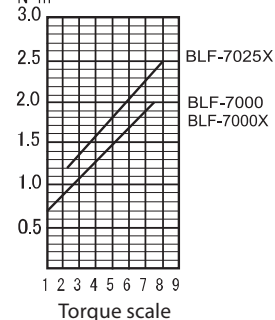

\* BLF-2000 includes two Torque Adjustment springs. The silver spring is for high torque, while the black spring installed to the main body is for low torque.

Please use the right spring according to your work.

● The above show the measurement results with a rotation speed of 30. Please use it as a reference.

● The torque values were measured by HIOS Torque Meter HP with a Fidaptor.

## Exterior dimensions and details of the screwdrivers

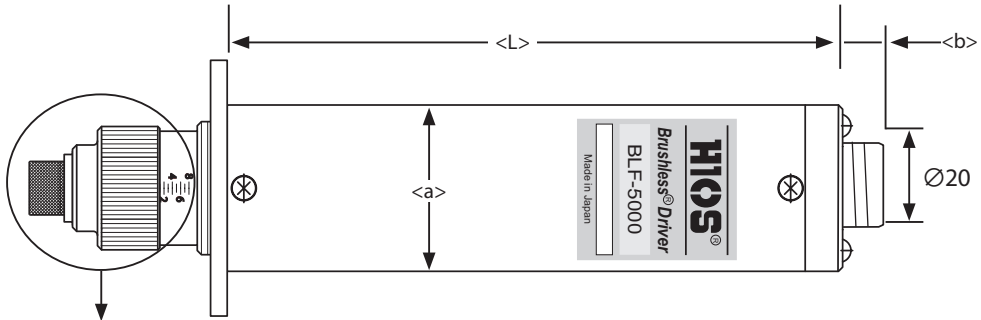

See the details for each machine type.

### Exterior dimensions

Model	<L> Total Length	<a> Diameter of body	<b> Connector height
BLF-2000	124mm	$\varnothing 38$	7mm
BLF-5000	148mm	$\varnothing 40$	6.7mm
BLF-7000			
BLF-7000X	160mm	$\varnothing 42$	6.7mm
BLF-7025X			

\* The concavity and convexity are not considered for the dimensions.

### Driver Cord Dimensions

- Part Number: BLF7-0612-VI
- Cord Length: 3m

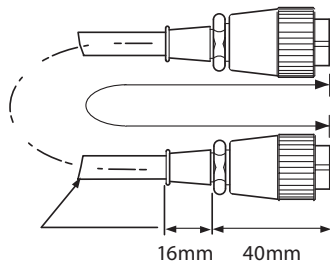

## Figure of installation dimensions

### BLF-2000 (H4)

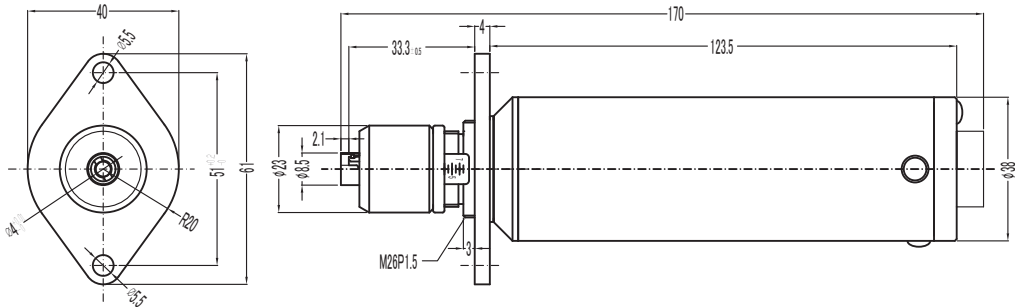

\* The flange can be removed by rotating it counterclockwise.

### BLF-5000 (H5)

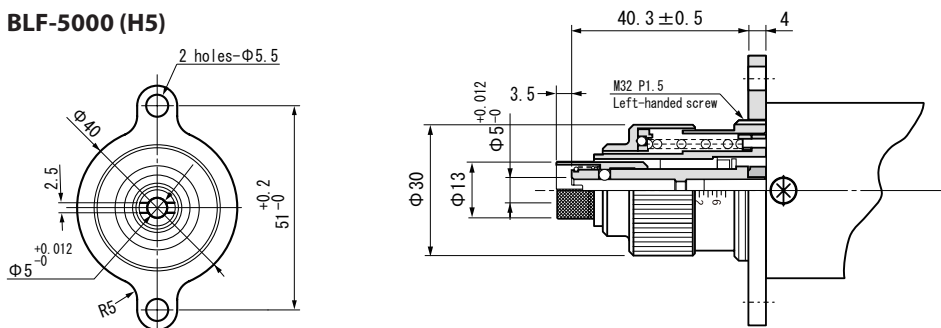

\* The flange can be removed by rotating it clockwise.

### BLF-7000 (H5)

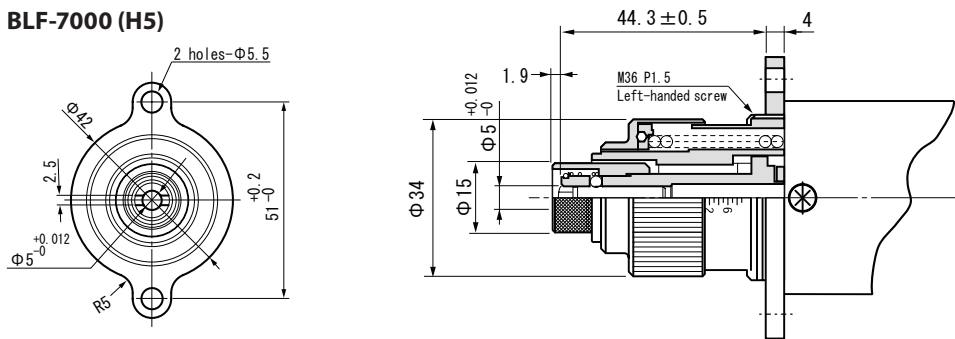

\* The flange can be removed by rotating it clockwise.

### BLF-7000X / BLF-7025X (1/4HEX)

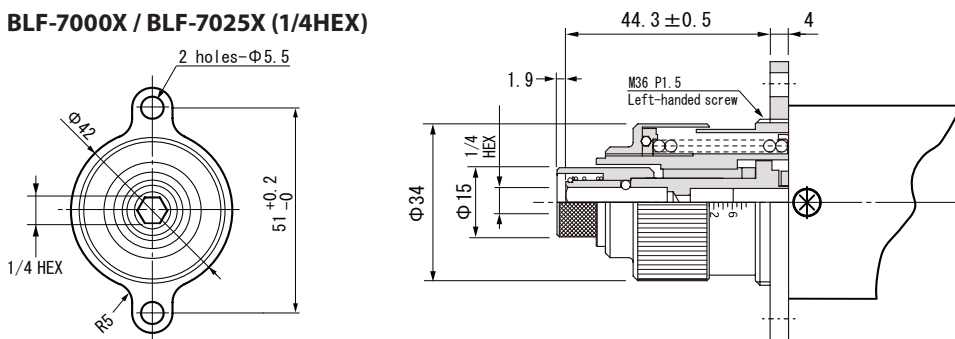

(Note) General tolerance is applied to the external dimensions without tolerance indication above.

## Suction (Vacuum) Attachment BLFQ series

As for vacuum pick up screwdriver, we deal with BLFQ (standard) and BLFR (custom-made)

Exterior view of BLFQ

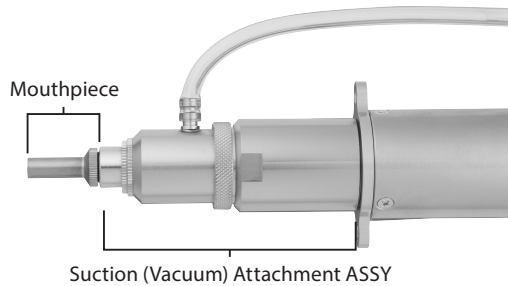

### BLFQ accessories list

Model	Mouthpiece		Bit		Suction Attachment ASSY	Accessories
	Model number	Length	Length (L)	Diameter	Model number	
BLFQ-2000	F3	18mm	60mm	HIOS H4(Ø4)	BLFQ2-SET	With Hose (Hose size: Inner diameter Ø4 × Outer diameter Ø7; Length: 3.5m)
BLFQ-5000	F6	31mm	100mm	HIOS H5(Ø5)	BLFQ5-SET	
BLFQ-7000	F6	31mm	100mm	HIOS H5(Ø5)	BLFQ7-SET	

\* When you use BLFQ series, please attach the mouthpiece / bit / Suction Attachments in the table (optional parts). Please contact us about the bit type of 1/4 HEX (hex bit with distance across the flats is 6.35 mm) for BLFQ-7000.

### Mouthpiece

The model numbers of the mouthpieces holding the screws are as follows:

F3 (supports BLFQ-2000)	F6 (supports BLFQ-5000 and BLFQ-7000)

### Adjustment of mouthpiece

(Only the mouthpieces of BLFQ series are adjustable.)

The length of the screw protrudes from the mouthpiece can be adjusted.

- 1 Rotate both the A part and B part at the same time to loosen.**
- 2 Rotate the A part to open the holder; you can then adjust the length of the screw protrudes from the mouthpiece.**
- 3 Once adjustment is completed, tighten the B part to lock while holding the A part.**

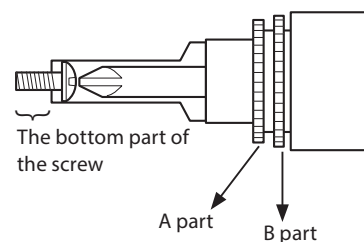

### Bits

The bits used in the Suction (Vacuum) Attachment are required to be longer (L length) than standard.

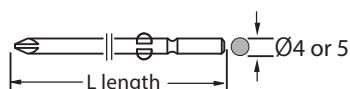

## Checking Supplied Accessories

If any items are missing or damaged, please contact the store where you purchased the product.

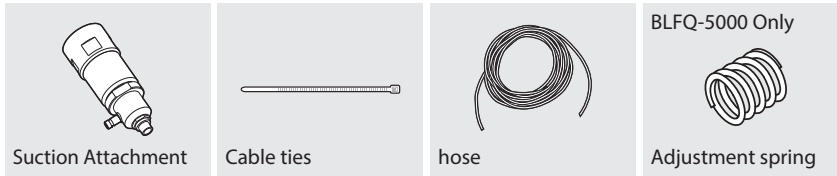

## Assemble the Attachments

- 1 Attach a bit as required.**
  - A bit longer than an ordinary one is preferable.

- 2 Attach the suction attachment.**

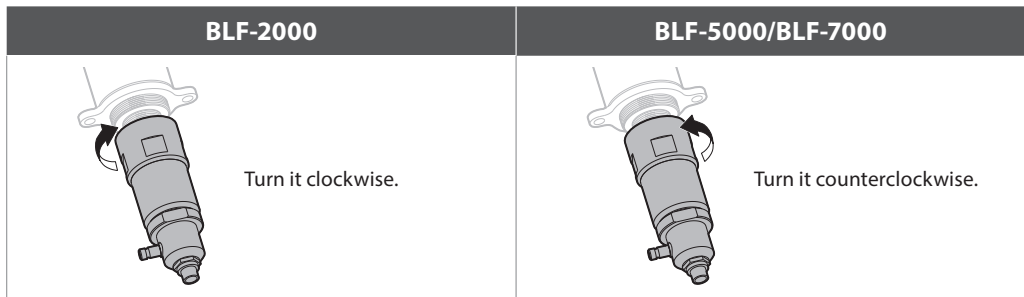

- 3 Attach a mouthpiece.**

- Turn it clockwise.



- 4 Connect the hose.**

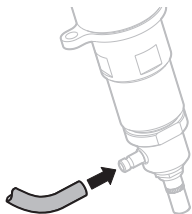

## Replace the Torque Adjustment Spring (BLFQ-5000 Only)

If you need torque below the standard torque range, use the included low torque spring.

### CAUTION

- Do not install or remove the torque adjustment spring while the power is on. It may cause an unexpected accident.

### 1 Remove the hose.

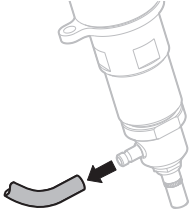

### 2 Remove the suction attachment.

- Turn it clockwise.



### 3 Remove the bit.

- Remove the bit while pulling out the joint shaft collar from the screwdriver.

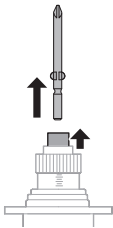

### 4 Remove the torque adjustment nut and torque adjustment spring holder and replace the torque adjustment spring.

#### CAUTION

- When replacing the torque adjustment spring, be careful not to get your clothes or hands dirty with grease.

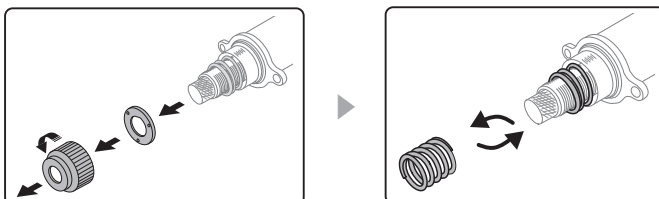

### 5 Replace the removed parts.

## Suction (Vacuum) Attachment BLFR series

### Outline

This attachment is designed to be installed in robots and makes torque adjustment and bit replacement easier. Because replacement is not required, it is optimal for robots. This attachment can be effectively used for difficult screw fastening positions including deep holes where normal attachment interferes with fastening.

### NOTE

- If you use the BLFR screwdriver in a reverse rotation, be careful about loosening the bit because it is screwed on.

### Features of BLFR screwdriver

- The BLFR Mouthpiece is double mouthpiece structure with a spring. There are 2 types of those. One is a self-adjustable inner mouthpiece type. The other one is a self-adjustable outer mouthpiece type. There is another special mouthpiece that does not touch work piece which prevents work piece from damaging.
- Compared with the existing HIOS Mouthpiece, the ultimate vacuum of the BLFR Mouthpiece is higher which helps to reduce vacuum screw errors.
- The edge of the BLFR Mouthpiece touches parallel to the screw head which improves uprightness of the screw.
- The long Bit Holder prevents cross threaded screws.

Exterior view of BLFR

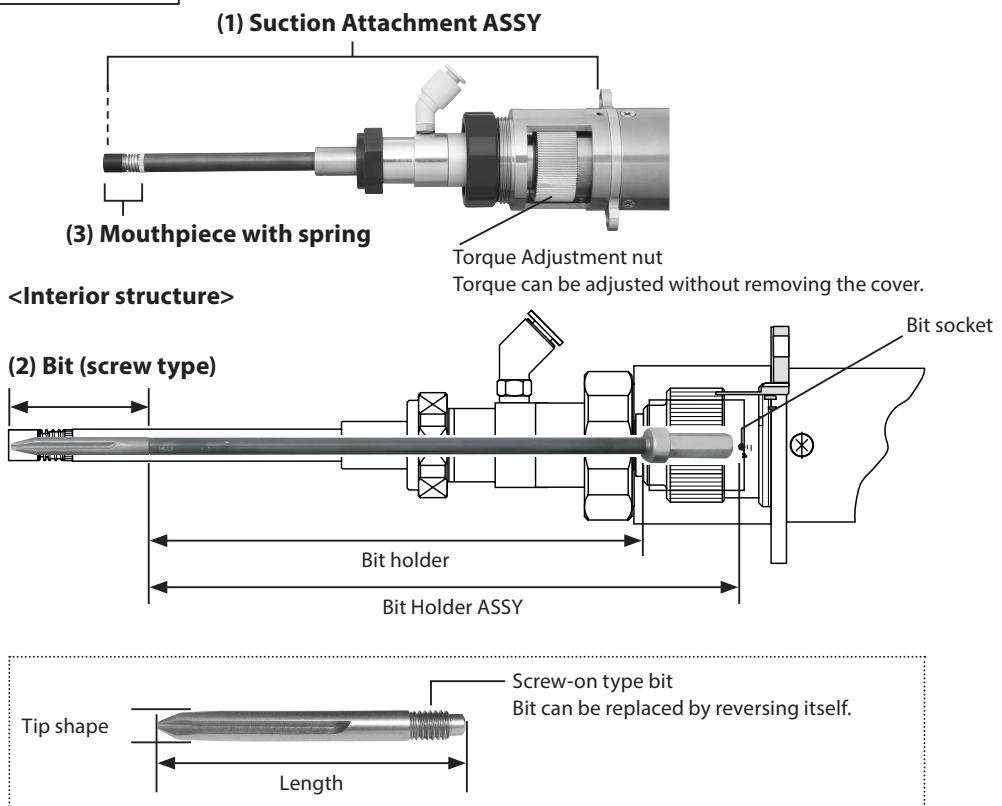

### BLFR accessories list (Table 1)

Model	(1) Suction Attachment ASSY	(2) Bit (Screw Type)				Bit Holder ASSY			
	Order Code	Tip Shape	Order Code	Length	Diameter	Order Code	Length	Bit drive	
BLFR-5000	BLFR5-SA	+	#1	RBP4140S	40mm	Ø4	BLFR5-3060	122.8 mm	5HEX
			#2	RBP4240S					
BLFR-7000X	BLFR7-SA	+	#1	RBP4140S	40mm	Ø4	BLFR7-3060	122.8 mm	1/4HEX
			#2	RBP4240S					
BLFR-7025X	BLFR7-SA	+	#1	RBP4140S	40mm	Ø4	BLFR7-3060	122.8 mm	1/4HEX
			#2	RBP4240S					

\* The hose is optional. (Hose size: Inner diameter Ø4.6 × Outer diameter Ø6; Hose length: 3.5m)

• Please refer to the cross recess size and screw size below.

#0 (M1.4 - M1.7) #1 (M2.0 - M2.6) #2 (M3.0 - M5.0)

**Please check below before purchasing the BLFR series:**

BLFR accessories list (Table 1): (1) Suction Attachment ASSY, and (2) Bit, and

Size of spring-loaded mouthpiece suitable for operation (Table 2) need to be selected.

Please refer to pages 16 and 17 for the type of spring loaded mouthpiece and applicable screws to select the most suitable size for your work.

(Accessories are optional.)

\* If you have any questions, please contact us.

## Identification of the BLFR Mouthpiece Order Code

**F S 6 0 – 8 0 J**

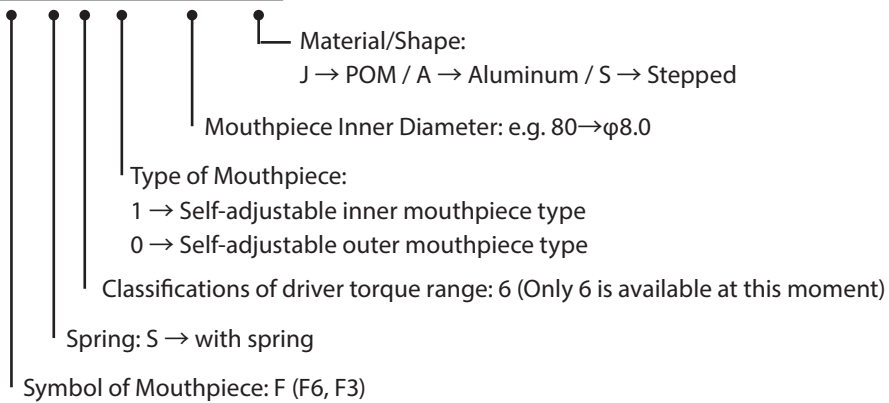

## Types of spring loaded mouthpiece (attachable to BLFR-5000 and BLFR-7000 series)

### Self-adjustable inner mouthpiece type

Order Code: FS61-68

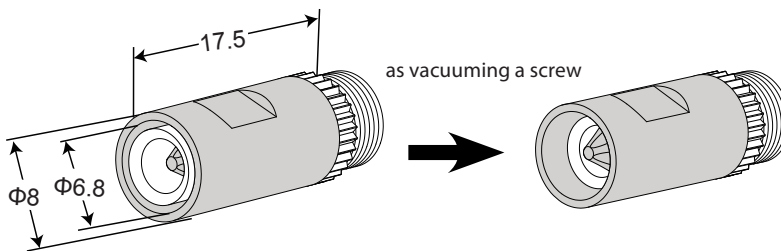

Order Code: FS61-68S

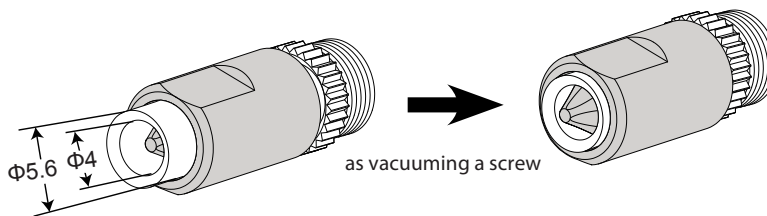

Order Code: FS61-74

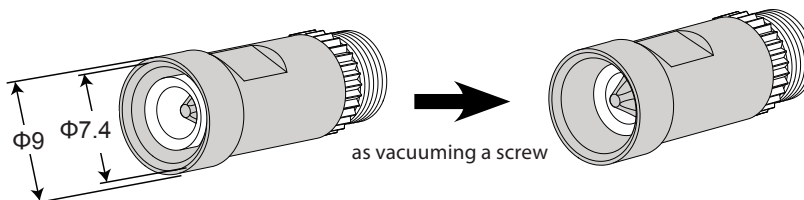

\* Neither the inner mouthpiece (FS61-68S) nor the outer mouthpiece damage the workpiece during operation, because they can pick up screws without touching the workpiece.

● **Self-adjustable outer mouthpiece type**

Order Code: FS60-68J / FS60-68A

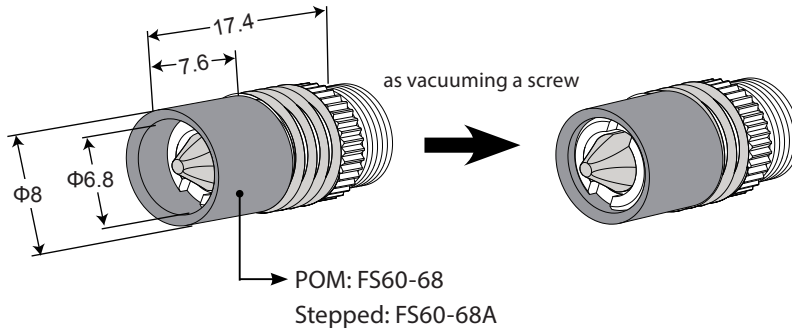

Order Code: FS60-80J

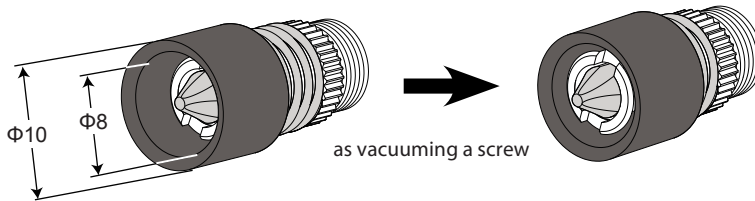

**Adaptive screw size indications (Table 2)**

Screw Size		M2.6			M3.0			M4.0		
Screw Type		Pan	Binding	Truss	Pan	Binding	Truss	Pan	Binding	Truss
Model	BLFR-5000	FS61-68 FS61-68S			FS61-68 FS61-68S	FS61-68S FS61-74	FS61-74	-	-	-
	BLFR-7000X				FS60-68J / FS60-68A			-	FS60-80J M4.0 or larger	-
	BLFR-7025X				FS60-68J / FS60-68A			-	FS60-80J M4.0 or larger	-

● **Movements of the inner mouthpiece**

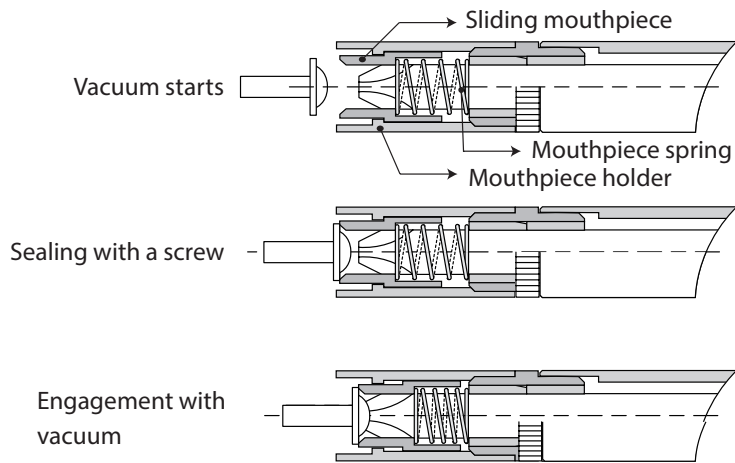

The sliding mouthpiece moves horizontally to hold the screw head and keeps it straight.

● **Movements of the outer mouthpiece**

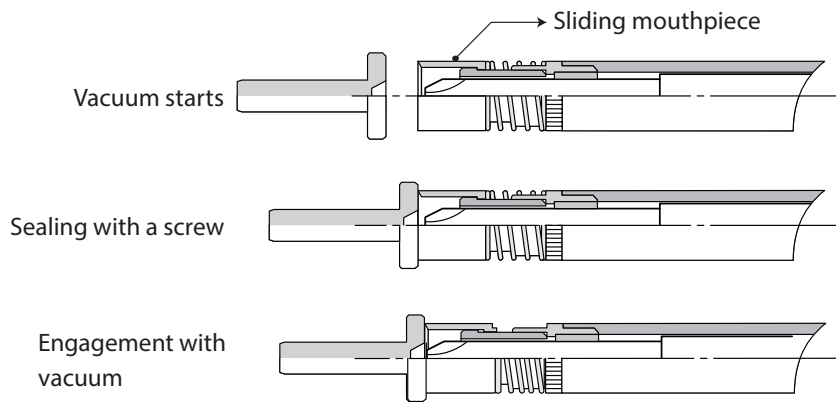

The sliding mouthpiece moves horizontally to hold the screw head and keeps it straight.

\* Because the mouthpiece is thinner than the screw's outer diameter, you can effectively fasten the screw in a narrow space.

● **Comparison in case of screw fastening at a slant:**

e.g.) 4mm screw is tightened with the pilot hole deviated from the straight position by 1.5mm.

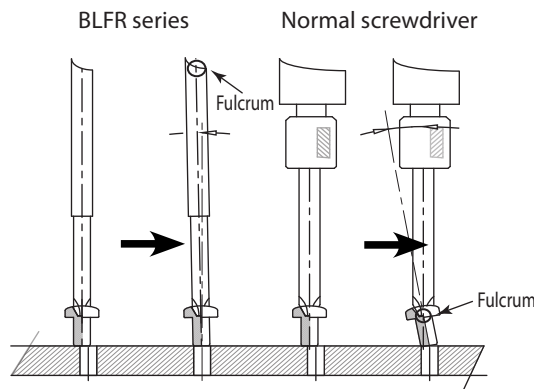

- The screw doesn't fall because of the high fulcrum.
- The screw falls because of the deviation of the pilot hole.

\* With a long bit holder, a screw doesn't fall and slanted fastening can be prevented.

## ● Variations

Length of mouthpiece + holder

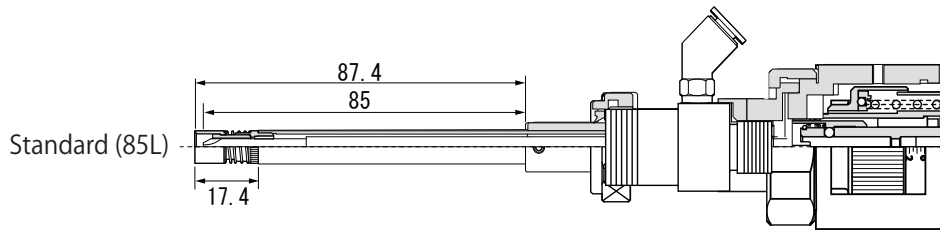

- The standard total length of a mouthpiece and a holder is 85L. 32L, 56L, 60L, 95L and 125L are available as customized specifications.

For deeper holes

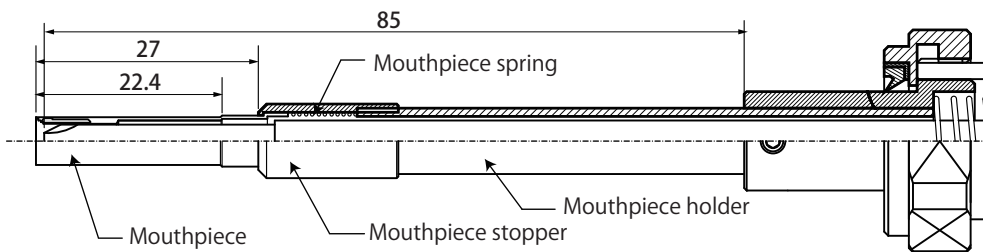

- For deeper holes, the mouthpieces of 41L and 61L are available in addition to 27L.
- Furthermore, for a hole depth of 2.6 mm or smaller, we can prepare a customized mouthpiece. However, please note that because the customized mouthpiece becomes thinner toward the tip, the vacuum pressure tends to be weak.

\* The customized mouthpieces may take longer for delivery depending on the stock status. Please make an inquiry before placing an order.

## Exterior dimensions of the suction attachments

### NOTE

- These are not full-scale drawings. The drawings in dxf can be downloaded from HIOS website.

#### ● BLFQ-2000 (Mouthpiece: F3, Length: 18mm as standard)

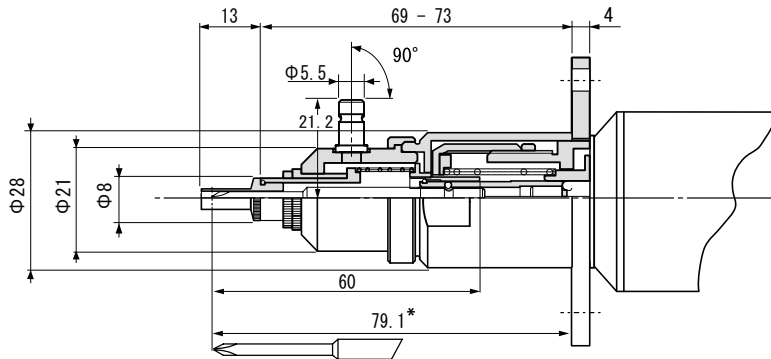

- For bit H4-60mm, dimension from tip of bit to flange is 79.1mm
- Dimension of \*part depends on the actual length of bit.

#### ● BLFQ-5000 (Mouthpiece: F6, Length: 31mm as standard)

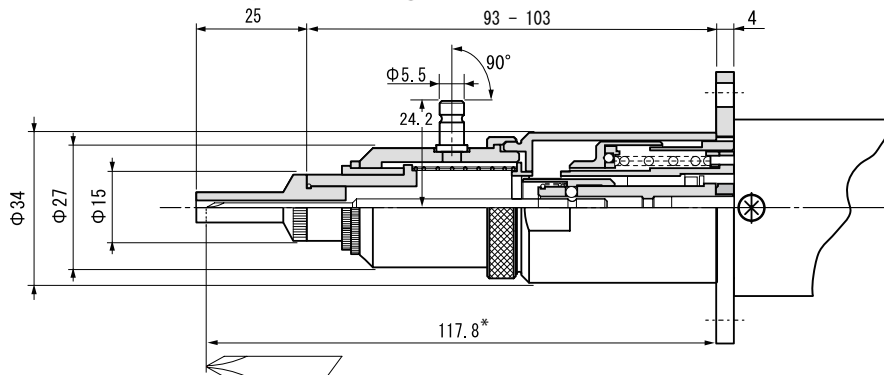

- For bit H5-100mm, dimension from tip of bit to flange is 117.8mm
- Dimension of \*part depends on the actual length of bit.

#### ● BLFR-5000 (installed FS60-68J)

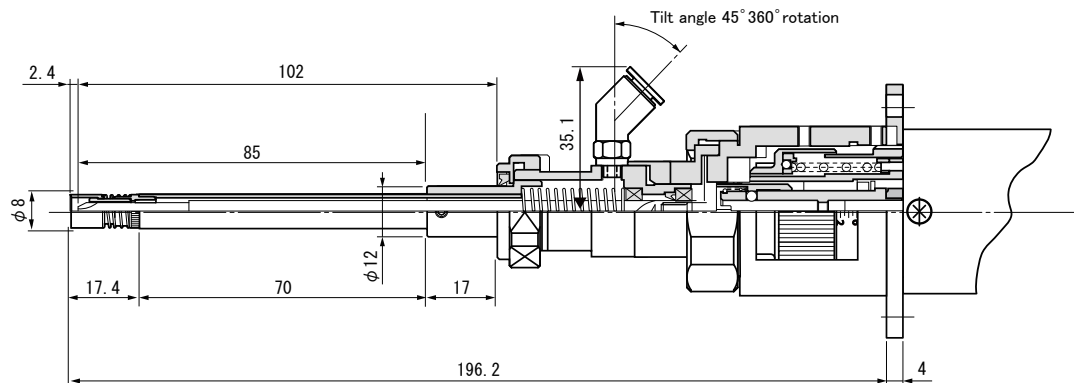

Unit: mm

● **BLFQ-7000 (Mouthpiece: F6 Length: 31mm as standard)**

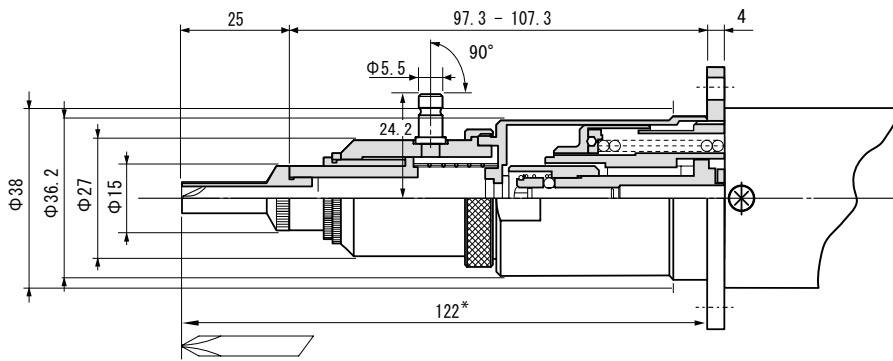

- For bit H5-100mm, dimension from tip of bit to flange is 122mm
- Dimension of \*part depends on the actual length of bit.

● **BLFR-7000X / BLFR-7025X (installed FS60-68J)**

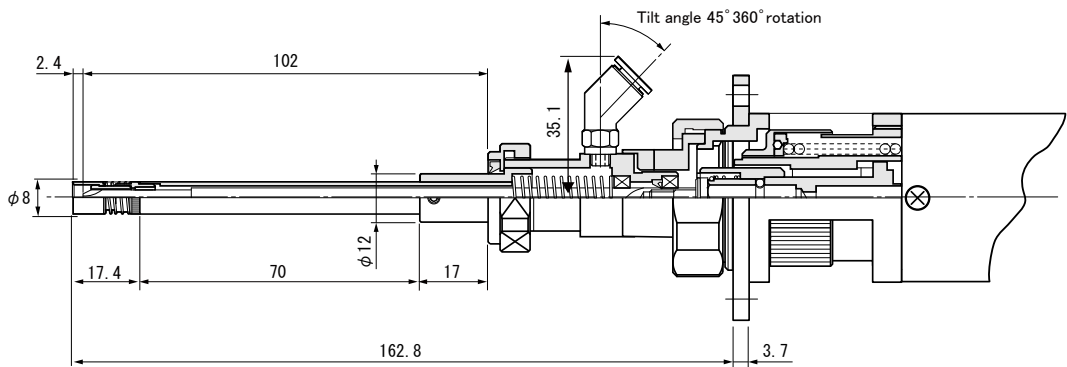

Unit: mm

## Vacuum Pump VP-3

To use the BLFQ and BLFR, Vacuum Pump VP-3 is required.

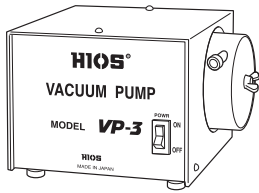

### Specifications of VP-3

Input on the primary side	AC100V,120V or 220-240V $\pm 5\%$
Power consumption	39 W
The maximum vacuum	-350mm Hg
Size	200×188×142 (H) mm
Weight	3.8kg







**HIOS Inc.**

---

1-35-1 Oshiage, Sumida-ku Tokyo, Japan 131-0045  
Phone: 81-3-6661-8821 FAX: 81-3-6661-8828  
[www.hios.com](http://www.hios.com)