

# HIOS®

Built-in screwdriver & Pulse system

## BLG-BC2 Series

BLG-4000BC2 / BLG-4000BC2-LT

BLG-5000BC2 / BLG-5000BC2-15 / BLG-5000BC2-18 / BLG-5000BC2-HT

BLG-7000BC2 / BLG-7000BC2-GT (-S/ -HANDLE)

## Operation Manual

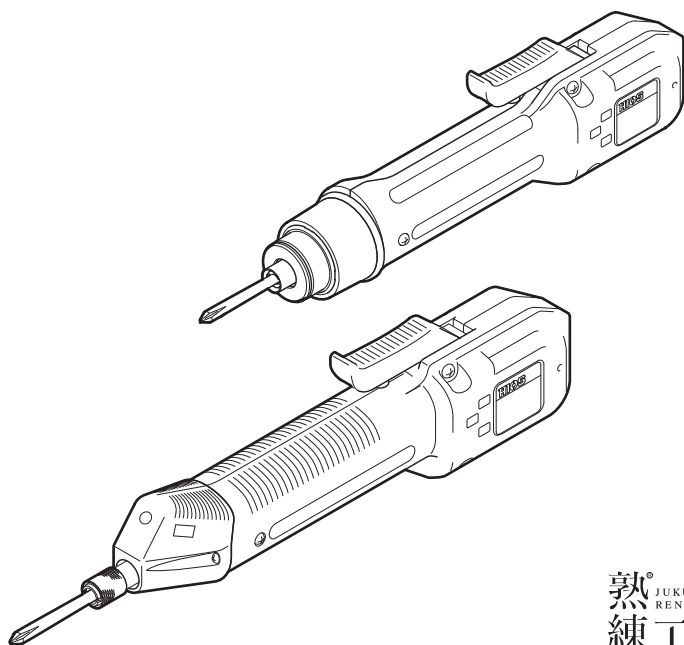

熟練工  
JUKU  
REN

## Table of Contents

### 03 Important Safety Instructions

### 05 Checking Supplied Accessories

### 06 Setting Up the Device

Connecting the Cord

Installing with the Stand (BLG-7000BC2-GT-S)

Attaching a Bit

Changing the Start Mode (for BLG-5000BC2 Series /BLG-7000BC2 Series)

BLG-5000BC2 Series

BLG-7000BC2 Series

### 10 Parts and Their Functions

BLG-4000BC2 Series

BLG-5000BC2 Series

BLG-7000BC2

BLG-7000BC2-GT (-S/-HANDLE)

Operation Panel

Stand / Handle

### 13 Basic Operations

How to Change Rotation Speed

### 14 Setting the Torque

BLG-4000BC2 Series

Output Torque Guide (HI Input)

How to Change to Smaller Torque

BLG-5000BC2 Series /BLG-7000BC2

Output Torque Guide (HI Input)

BLG-7000BC2-GT

Output Torque Guide (HI Input)

### 18 Setting the Pass / Fail Criteria

Setting by Direct Teaching

Setting by Manual Procedure

### 21 Setting Screw Counter

### 23 Setting Menu List

How to Operate Setup Mode

<Counter>

<Screw Counter>

<Minimum Pulse>

<Maximum Pulse>

<Work Reset Timer>

<Count Timer for Reverse Rotation>

<System>

<Pulse Detection>

<Total Torque-ups (count)>

<Inactive Time of Torque-up>

### 27 Connecting the Special Cable (Option)

Checking Supplied the Cable Accessories

Connecting to Screwdriver (BLG-4000BC2/  
BLG-5000BC2 Series)

Connecting to Screwdriver (BLG-7000BC2)

### 31 Saving Screw Fastening Data

System Requirements

Screen of Connection

Connecting to Screwdriver

Sending Command

Work Monitor

Screen of Administration

Specifications of Communication by Special  
Cable

Message Format

Communication Command / List of  
Messages

### 43 Troubleshooting

Common Problems

When the Messages Below Are Displayed

Want to See the Device Version

### 45 Maintenance

About BLG-7000BC2-GT

### 46 Specifications

BLG-4000BC2 Series

BLG-5000BC2 Series

BLG-7000BC2

BLG-7000BC2-GT

### 51 Notice

# Important Safety Instructions

Please read this manual and the power supply unit manual carefully before use to ensure proper operation. In addition, do not use the product in the way not described in this manual. Please note that we are not responsible for any problems caused by using the product in a manner that does not conform to the contents of this manual, using it improperly, or repairing / modifying by a third party except by us or someone specified by us.

## Installation

---

- Do not install the device at the places described below. Otherwise, it may cause a fire or a failure.
  - A place of high humidity or with a lot of dust
  - A place where it becomes high temperatures
  - A place of fire
  - A place of direct sunshine
  - A place containing corrosive gas in the air
  - Unstable place
- Do not use the device where the ambient temperatures are out of the range of 5 to 40 °C.

## Power Supply

---

- Be sure to install an earth leakage breaker and a safety breaker on the commercial power source before using it.
- Connect the earth wire to the earth wire terminal of the outlet. You may have an electric shock without the earth wire connection in case of an electric leakage.
- Avoid the octopus foot wiring and use of an extension cord. Otherwise, it may cause a fire or an electric shock.
- Do not connect anything other than specified to the connection part of this device. Otherwise, it may cause an electric shock or a failure.

## Handling

---

- Do not wear clothes with flippers on the cuffs, gloves, neckties etc. Otherwise, they may get caught in the rotating screwdriver and cause an injury or a failure.
- Wear suitable clothing and protective eye-wear for work. Cover long hair with a hat etc. so that you can work safely.
- Turn off power when you leave the workplace, or when you attach / remove a bit / an optional item.
- If static electricity is charged, you need to neutralize it before use.
- Avoid an unstable place or an unreasonable posture for work. Otherwise, it may cause an injury.
- Long-time work or some types of work may cause strain on your hands, neck, arms or waist, causing an injury. Avoid long-time work and take a break regularly.
- We recommend use of a balancer to prevent the device from falling and to protect cords / wires.
- Hold the plug when you attach / remove the power cord, screwdriver and so on.
- Protect cords / wires by not giving damages to them; not remodeling them; not pulling them; not bending them forcibly; etc. Also, do not place heavy items on the power cord. Otherwise, it may cause a fire or an electric shock.
- If you detect an uneven rotation, strange noises, overheating or activation of a breaker, etc., stop using the device immediately and have it repaired.

However, note that the device may be overheated depending on the frequency of the workpiece or screw types. As a countermeasure, prepare spare screwdrivers of the same model to extend the tact time and use them alternately, or review the selection of screwdriver models.

- Do not overload the device so much that it cannot clutch. Otherwise, it may cause a failure of the motor.
- Do not touch the screwdriver while it is rotating. Otherwise, it may cause an injury or a failure.
- Keep your hands and face away from the rotating section while in use. Otherwise, it may cause an injury.
- Remove the bit from the screwdriver when you are not working.
- If you cannot attach / remove the bit in the way described in this document, please make contact with our service section.
- Fix the workpiece with jig / clamp while in working.
- Do not use the switch lever as a hanger. Otherwise, it may cause an accident or an injury.
- Do not give a strong impact or excessive force. Otherwise, it may cause a failure.
- Do not operate the screwdriver with wet or oiled hands.
- Do not operate the FOR / REV switch before the screwdriver completely stops. Otherwise, it may cause a failure.
- Do not disassemble / remodel this device. Otherwise, it may cause a failure.
- High torque has a large recoil on the hand or arm. Hold the driver firmly to avoid being swung around.
- Do not work with the attached anti-reaction stand or handle removed. It may cause an accident or injury.

## Maintenance and Inspections

---

- Turn off power and remove the power plug from the outlet when the device is not in use for a long time.
- Remove the accessories from the screwdriver and store them in the package box when it is not in use them for a long time.
- Inspect the device regularly to confirm there are no damages. If you use it with damages, it may cause a fire or an electric shock.
- When you clean the device, turn off the power and remove the power plug from the outlet. Otherwise, it may cause a fire or an electric shock.
- Use dry cloth to wipe of dust or stains. The dust may absorb moisture to allow current to flow, causing a fire.
- Store the device in a place where the appropriate temperatures and humidity are controlled.
- Do not store the device in an unstable place or a place with vibrations. Otherwise, it may cause a failure.
- Keep the device out of reach of anyone but people involved in the workpiece.
- We recommend genuine HIOS parts for replacement.

# Checking Supplied Accessories

One bit for each socket



Bit Drive	4000BC2-LT	4000BC2	5000BC2 5000BC2-15	5000BC2-18 5000BC2-HT 7000BC2	7000BC2-GT
<b>H4</b>	+ #0 (Ø2.0×40mm) + #0 (Ø2.5×40mm)	+ #0 (Ø2.5×40mm) + #1 (Ø4.0×40mm)	+ #1 (Ø4.0×40mm) + #2 (Ø4.0×40mm)	-	-
<b>H5</b>	-	-	+ #1 (Ø5.0×60mm) + #2 (Ø5.0×60mm)	+ #1 (Ø5.0×60mm) + #2 (Ø5.0×60mm)	-
<b>1/4 HEX</b>	-		+ #1 (Ø5.0×50mm) + #2 (Ø5.0×50mm) - (Ø5.0×50mm)		+ #2 (Ø7.0×100mm) + #3 (Ø7.0×100mm)

Screwdriver cord: 2 m (6P)



Hexagon L-shaped wrench: 5 mm across flats  
(BLG-5000BC2 Series/BLG-7000BC2 Only)

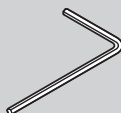

Adjustment spring for low torque  
(BLG-4000BC2/BLG-4000BC2-LT Only)



Instruction manual

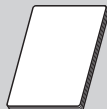

**HANDLE (BLG-7000BC2-GT-HANDLE)**  
\*Attached to the driver

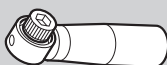

**Stand (BLG-7000BC2-GT-S)**  
\*Slide arm is attached to the driver

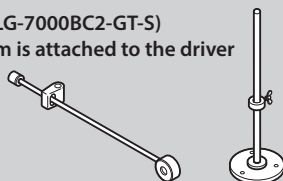

# Setting Up the Device

## Connecting the Cord

### 1 Connect the screwdriver cord to the power unit and the screwdriver.

- Use the joint ring for fixing to prevent the cord from coming off.



### 2 Connect the power unit cord to the power unit and the outlet and turn on the switch.

- The indicator on the power unit turns on.

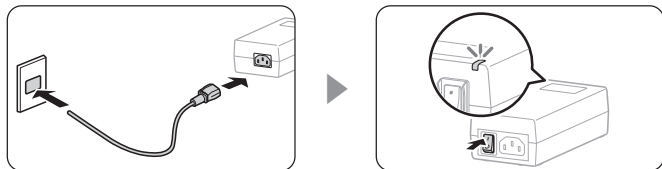

## Installing with the Stand (BLG-7000BC2-GT-S)

### 1 Fix the stand, then put the shockless holder on the pole.

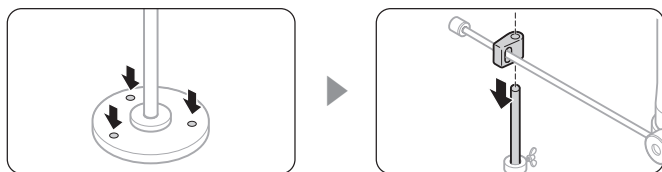

### 2 Adjust the position of the slide arm if needed.

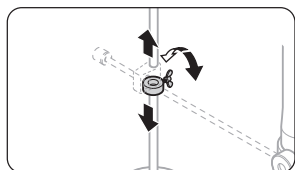

## Attaching a Bit



### Caution

Do not attach / remove the bit while power is on. Otherwise, it may cause an unexpected accident.

### 1 Insert the bit into the joint shaft collar.

- BLG-4000BC2 / BLG-4000BC2-LT: Attach the bit while pushing the joint shaft collar into the screwdriver.
- BLG-5000BC2 Series / BLG-7000BC2: Attach the bit while pulling out the joint shaft collar from the screwdriver.

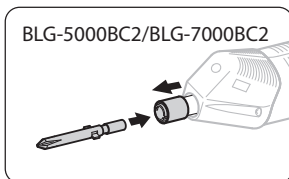
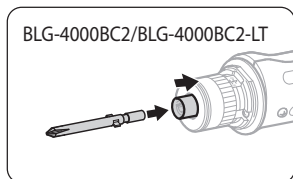

### 2 Confirm the bit has been attached firmly by pulling it light.

#### Precaution for Use of Hexagonal Bit

You cannot use a double head bit with double grooves. Prepare suitable sockets for those bits.

Bit Socket	5HEX (5 mm across flats)	1/4HEX (6.35 mm across flats)
Type	<p>5 14.0</p>	<p>6.35 9.0</p>

## Changing the Start Mode (for BLG-5000BC2 Series /BLG-7000BC2 Series)

You can change the mode to push start for BLG-5000BC2 Series and BLG-7000BC2. In the push start mode, the screwdriver starts rotation when you press it into an object.

### BLG-5000BC2 Series

#### 1 Remove the switch lever.

- Remove the shaft screw.
- Be careful not to lose the lever spring.

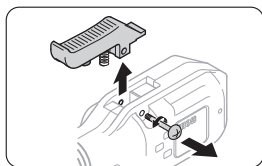

#### 2 Change the start mode.

- Use something pointy such as a pen.

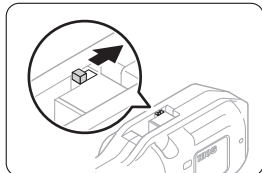

#### 3 Re-attach the shaft screw.

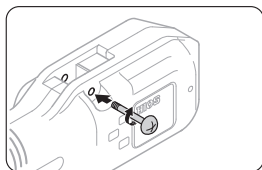

#### Caution

- Do not give a strong impact to the start mode switch. Otherwise, it may cause a failure.
- Do not use the screwdriver while the shaft screw is not fixed. Otherwise, it may cause a failure.
- Do not overtighten the shaft screw as this may cause the lever to break.

## BLG-700BC2 Series

### 1 Remove the switch lever.

- Remove the shaft screw.
- Be careful not to lose the lever spring.

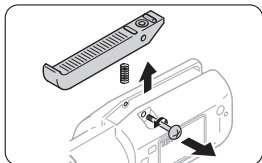

### 2 Turn over the switch lever and attach it.

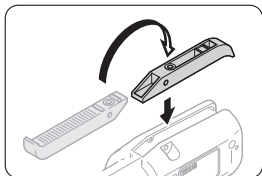

### 3 Re-attach the shaft screw.

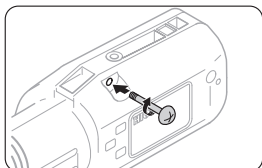

#### Caution

- Do not overtighten the shaft screw as this may cause the lever to break.

# Parts and Their Functions

## BLG-4000BC2 Series

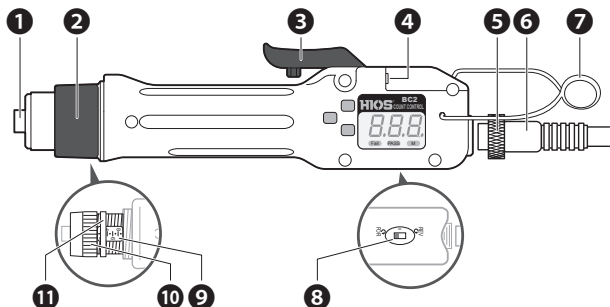

## BLG-5000BC2 Series

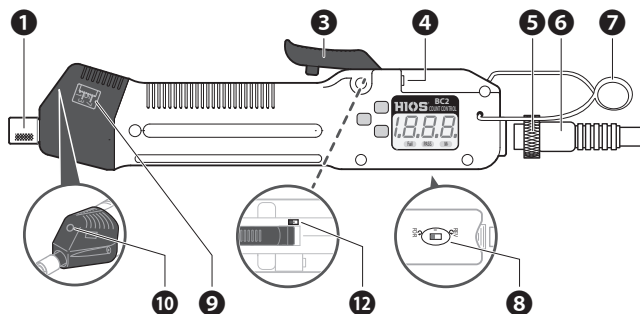

### 1 Joint shaft collar

This is to be used to attach the bit or remove it.

### 2 Protection cover of torque adjustment nut

This can be removed by turning it counterclockwise.

### 3 Switch lever

This is used to start the screwdriver.

For 7000BC2, if you attach the lever upside down, you can use the push start.

### 4 External I/O port

Send / receive the data via this port with the special cable (option). You can change the set

values of the screwdriver from an external device (e.g. PC, PLC, etc.) and send out screw fastening data.

### 5 Joint ring

This is to prevent the screwdriver cord from coming off unexpectedly.

### 6 Screwdriver cord

This is to connect the screwdriver to the power unit. The plug on one end is the same as that on the other end.

### 7 Hanger

This is used to hang the screwdriver from the balancer.

## BLG-7000BC2

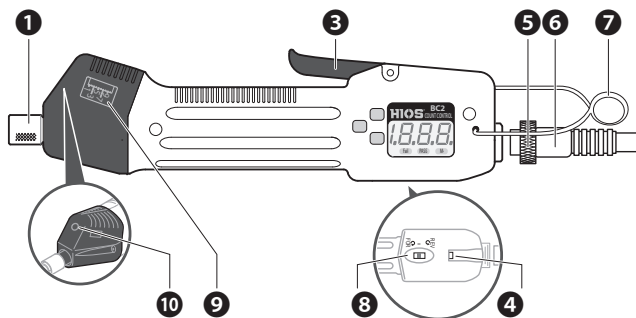

## BLG-7000BC2-GT (-S/-HANDLE)

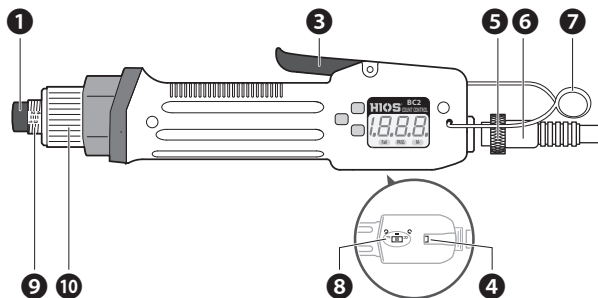

### ② FOR/REV switch

You can change the rotational direction with this switch.

- FOR: Clockwise
- 0: Neutral
- REV: Counterclockwise

### ⑨ Adjustment scale of torque

This is used as a guide for output torque adjustment. For details, refer to "Setting the Torque" (P. 14).

### ⑩ Torque adjustment nut

This is used for output torque adjustment.

### ① Nut fixing ring (BLG-4000BC2-LT Only)

This prevents the torque adjustment nut from moving improperly. Fit it closely with the torque adjustment nut.

### ④ Start mode change switch

This is used to change the start mode.

- L: Lever start
- P: Push start

For details, refer to "Changing the Start Mode (for BLG-5000BC2 Series /BLG-7000BC2 Series)" (P. 08).

## Operation Panel

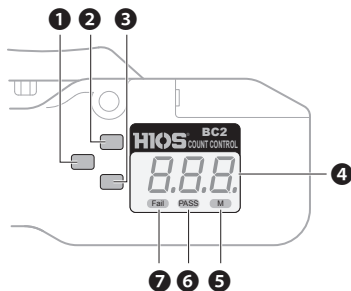

### 1 F1 button

This is used to change the mode to setting or change the setting items.

### 2 F2 button

This is used to change the mode to direct teaching or change the digit of the setting.

### 3 F3 button

This is used to change the setting.

### 4 Display

This displays the number of pulses, the operational conditions of the screw counter, error conditions and etc. In addition, you follow the instructions on the display during setup.

### 5 M indicator

This turns on when operations on the button are inactive. In addition, it blinks in the mode of temporary fastening (option).

### 6 PASS indicator

This turns on when the result of fastening a screw is accepted.

### 7 Fail indicator

This turns on when the result of fastening a screw is not accepted.

### 8 Pole

Adjust the position of the collar.

### 9 Wing screw

Fix the collar.

### 10 Slide arm

Absorb the impact of screw fastening.

### 11 Collar

Adjust the position of the slide arm.

### 12 Stand base

Fix on the work table.

### 13 Shockless holder

Attach slide arm to the pole.

### 14 Handle fixing bolt

fixing handle to the driver.

### 15 Handle

Grip firmly.

## Stand / Handle

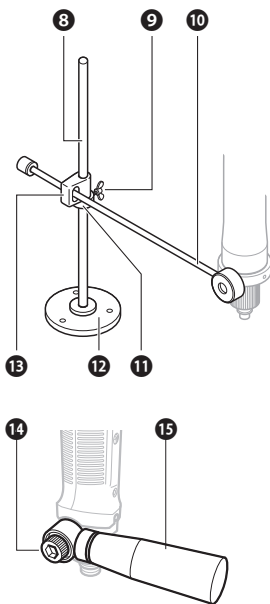

# Basic Operations

## 1 Set the FOR / REV switch to <FOR>.

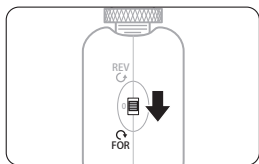

- When you change the rotational direction, turn the switch to 0 to stop the screwdriver.

## 2 Start the screwdriver.

- In the lever mode, pull the switch lever for start.
- In the push mode, push the screwdriver in the direction of the bit.
- Grip firmly if it is handle type.

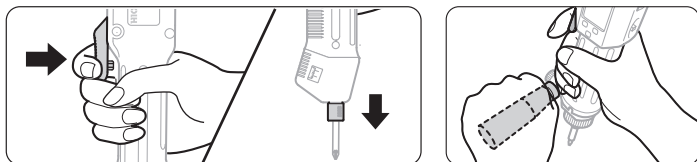

- When the screwdriver starts, the pulse is counted, and PASS / Fail is indicated by the sound and the indicator.



- In case of over 1000 pulses, <----> is displayed. For details of how to set pass / fail, refer to "Setting the Pass / Fail Criteria" (P. 18).
- When a screw is seated, the clutch is activated to stop rotation.
- If you restart the screwdriver, the PASS / Fail indicator turns off.

## How to Change Rotation Speed

When you want to change the rotation speed, use the switch for voltage output setting on the power unit.

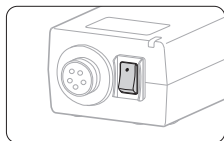

- 2: HI (30V)
- 1: LOW (20V)

# Setting the Torque

The torque can be adjusted by pushing the torque adjustment spring with pressure. If you turn the torque adjustment nut clockwise, the torque becomes large, and you turn it counterclockwise, it becomes small.



## Caution

"Output Torque Guide" and the torque adjustment scale should be considered as a guide; they do not guarantee actual torques. Use the torque meter by HIOS to check the torque precisely.

## BLG-4000BC2 Series

### 1 Remove the protection cover of the torque adjustment nut.



### 2 Turn the torque adjustment nut to set the fastening torque.

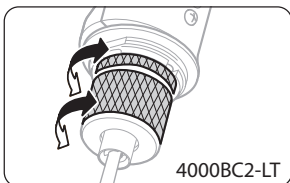
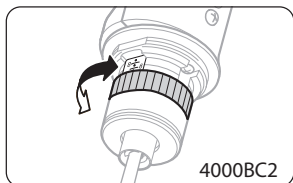

- Adjust the edge face of the torque adjustment nut to come right above the scale.
- For BLG-4000BC2-LT, adjust the edge face of the nut fixing ring to come right above the scale. When the nut fixing ring's position is determined, align the torque adjustment nut just to fit to the ring.

### 3 Re-attach the protection cover of torque adjustment nut.

## Output Torque Guide (HI Input)

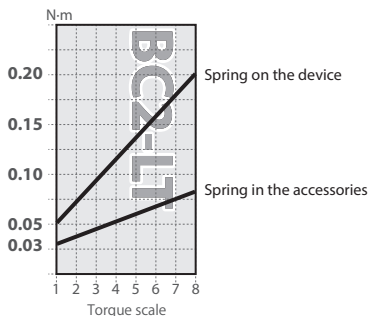
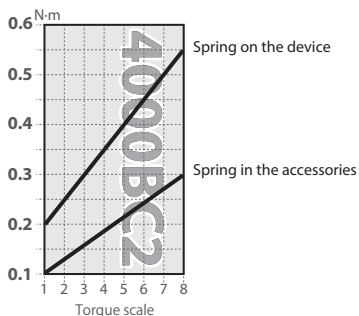

## How to Change to Smaller Torque

If you use the torque adjustment spring in the accessories, you can change the torque value smaller. Change the spring depending on the work conditions.

- 1 Remove the torque adjustment nut and the spring holder and replace the torque adjustment spring.**

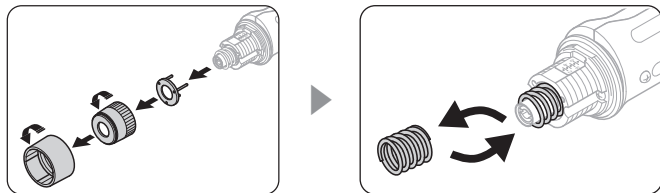

- 2 Re-attach the torque adjustment nut and the spring holder.**

- Attach the spring holder along the notch.

## BLG-5000BC2 Series /BLG-7000BC2

- 1 Use the hexagon L-shaped wrench in the accessories to turn the torque adjustment nut for setting the fastening torque.

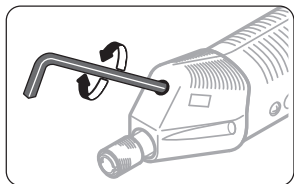

- Adjust the edge face of the torque adjustment nut to align with the scale.

### Output Torque Guide (HI Input)

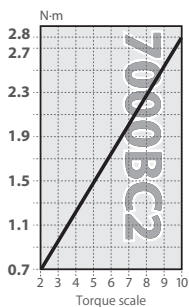
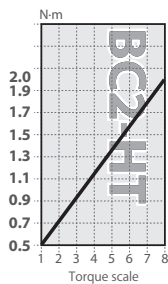
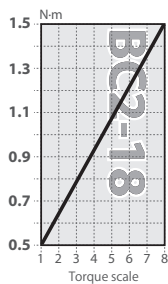
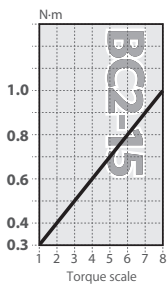
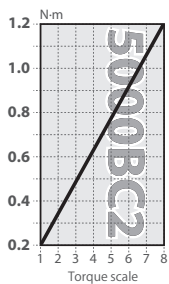

## BLG-7000BC2-GT

### 1 Rotate torque adjusting nut to set torque.

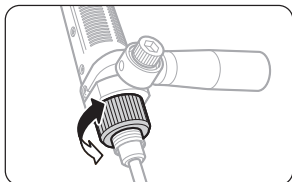

- Adjust the edge face of the torque adjustment nut to align with the scale.

### Output Torque Guide (HI Input)

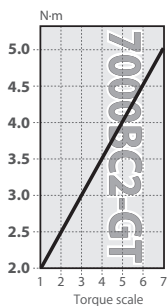

# Setting the Pass / Fail Criteria

This section describes how to set the pass / fail criteria. There are two ways of setting, direct teaching and manual setting.

## Setting by Direct Teaching

Direct teaching uses real screws and workpieces. It measures the pulses of motor rotation from when the screwdriver starts turning to when it reaches the torque-up. The maximum and the minimum measurements of pulses are set as the thresholds for pass / fail. Considering the measurement errors, you can set allowable ranges on thresholds.

Example: Minimum pulse = 100, Maximum pulse = 120, Allowable range = +/-10%

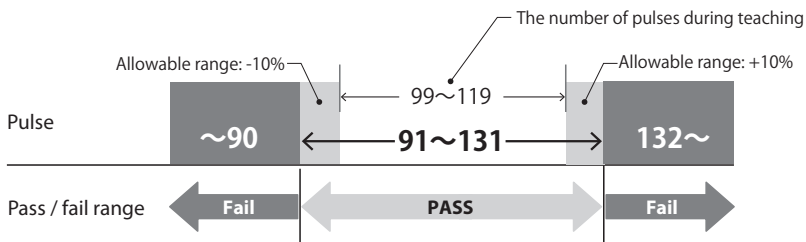

### Caution

- Do not use the conditions (i.e. screws, workpieces, etc.) for teaching different from those of real operation. Otherwise, it may cause larger errors.
- Before teaching you need to define the home position by fastening a screw.

## 1 Press and hold the F2 button.

- The Fail and PASS indicators start blinking.



## 2 Fasten a screw to a workpiece.

- The pulse is counted until the screw is seated.
- Repeat this teaching process at least three times.

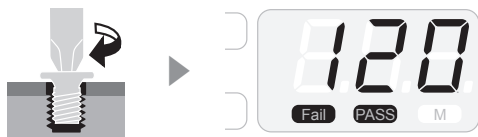

## 3 Press and hold the F3 button to set the allowable range of the threshold.

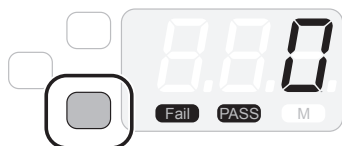

- Every time you press the F3 button, the allowable range changes.  
±0% ▶ ±5% ▶ ±10% ▶ ±15% ▶ ±20% ▶ ±0% ▶ ...

## 4 Press the F1 button to confirm the allowable range.

- The number of pulses is changed to the one with the tolerance factor calculated on both thresholds.



## 5 Press and hold the F2 button.



- The buzzer starts to indicate setting is finished.
- The number of screws to be fastened is displayed.

## Setting by Manual Procedure

Input the number of pulses directly to set the criteria.

### Caution

If you set the criteria manually, the factor of allowable range has no effect. Then, you need to set the number of pulses considering the variances of screws and workpieces.

### 1 Press and hold the F1 button.



### 2 Press the F1 button to select <Minimum Pulse> and enter your target number.



- If you press the F3 button, the number of the selected digit is changed.
- If you press the F2 button, you can move to another digit. The third digit is displayed by scrolling on the screen.

### 3 Press the F1 button to select <Maximum Pulse> and enter your target number.

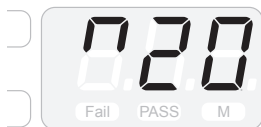

- If you press the F3 button, the number of the selected digit is changed.
- If you press the F2 button, you can move to another digit. The third digit is displayed by scrolling on the screen.

### 4 Press and hold the F1 button.

- The buzzer starts to indicate when the setting is finished.
- The number of screws to be fastened is displayed.

# Setting Screw Counter

Every time a screw is fastened correctly, the number of screws to be fastened on the display decreases (counting down). If the result is <Fail>, there is no counting down.

## 1 Press and hold the F1 button.

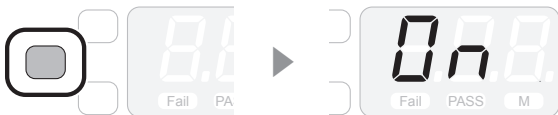

## 2 Press the F1 button to select <Screw Count> and enter your target number of screws.

- If you press the F3 button, the number of the selected digit is changed.
- If you press the F2 button, you can move to another digit.
- Enter a quantity from 1 to 99.



## 3 Press and hold the F1 button.

- The buzzer starts to indicate when the setting is finished.

## 4 Fasten a screw to a workpiece.

- If the result is <PASS>, the number of screws to be fastened decreases (counting down).

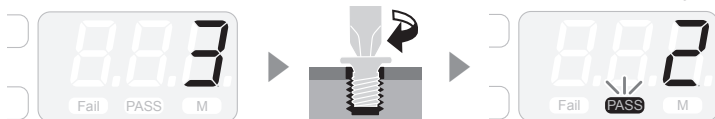

### Caution

- If you turn off the power while counting down, the device is reset to the set values.
- If you select the setup mode while counting down, the device is reset to the set values.
- If you use an external screw counter with this device, the screw counter does not synchronize. You can turn off the external screw counter and use it just as a power source.

### When the Set Number of Screws Is Reached

When counting down reaches the set number, the set number is displayed again.

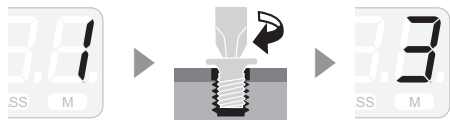

The buzzer starts when counting down reaches the set number. The time length of the buzzer can be specified via <Work Reset Timer>. For details, refer to “Setting Menu List” (P. 23).

### Counting in the Reverse Operation

If the reverse counting of <System> is active and operation exceeds the time specified by <Reverse Counting Timer>, the last counting down is cancelled. For details, refer to “Setting Menu List” (P. 23).

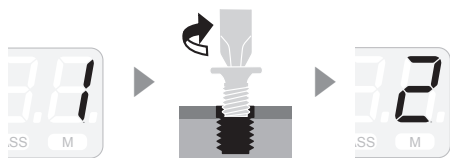

For the cancellation when the set number of screws is reached, reverse operation within the time specified by <Work Reset Timer> cancels counting down. For details, refer to “Setting Menu List” (P. 23).

### If You Want to Reset the Number of Screws to be Fastened to the Set Number:

Press and hold the F3 button and the device is reset to the set number.

# Setting Menu List

This device has various setup items and you can adjust each of them in detail.

The setup value in bold is the default.

## How to Operate Setup Mode

### Press and Hold the F1 Button to Start Setup.

Press and hold the F1 button to start setup.

Every time you press the F1 button, a new item appears.



### How to Change Setup

If you want to change the number of the selected digit or the setup value, press the F3 button.



If you press the F2 button, you can move to another digit. The third digit is displayed by scrolling on the screen if there is one.



### How to End Setup

Press and hold the F1 button.

## <Counter>

---

Here you can set whether to use all the functions including pulse counting, screw counter, etc. It sends out no data.



### Setup value

**On:** all the functions are used

**OFF:** the device is used as an ordinary screwdriver

## <Screw Counter>

---

Here you set the number of screws to be fastened.



### Setup value

1 to **5** to 99 screws

## <Minimum Pulse>

---

Here you set the lower threshold for pass / fail of screw fastening. If the number of pulses becomes smaller than the lower threshold, the result is <Fail>. To display the third digit, press the F2 button and scroll on the screen.

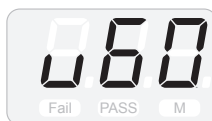

### Setup value

000 to **060** to 999 pulses

## <Maximum Pulse>

---

Here you set the upper threshold for pass / fail of screw fastening. If the number of pulses becomes larger than the lower threshold, the result is <Fail>. To display the third digit, press the F2 button and scroll on the screen.



### Setup value

000 to **120** to 999 pulses

## <Work Reset Timer>

Here you set the length of the buzzer when the number of screws set by <Screw Counter> is completed, and the reception time for cancellation of the final count down by reverse rotation.

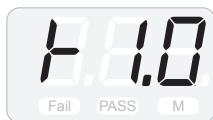

### Setup value

0.0 to **1.0** to 3.9 seconds

## <Count Timer for Reverse Rotation>

When the reverse counting of <System> is active, here you set the time for operation before you can cancel the last count down.

If you perform reverse operation of the device longer than the set time, the number of fastened screws of the last count down is to be counted up.



### Setup value

0.1 to **0.4** to 1.0 seconds

## <System>

This is used to set whether or not to use the buzzer sound for button operation and to use reverse counting.

This has no effect on the buzzer sound of direct teaching or <Fail>.



### Setup value<sup>A</sup>

**0: Buzzer is active; reverse counting is active**

1: Buzzer is active; reverse counting is inactive

2: Buzzer is inactive; reverse counting is active

3: Buzzer is inactive; reverse counting is inactive

### Setup value<sup>B</sup>

2: Buzzer for torque-up is inactive

**3: Buzzer for torque-up is active**

## <Pulse Detection>

---

This is used to set whether to detect an error of <Minimum Pulse> or <Maximum Pulse> in the judgment of pass / fail.

If you select no detection, the result always becomes <PASS>.

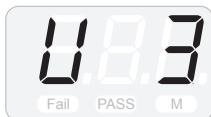

### Setup value

0: No error is to be detected both for <Minimum Pulse> and <Maximum Pulse>.

1: An error is to be detected only for <Minimum Pulse>.

2: An error is to be detected only for <Maximum Pulse>.

**3: An error is to be detected both for <Minimum Pulse> and <Maximum Pulse>.**

## <Total Torque-ups (count)>

---

This indicates the total torque-ups.

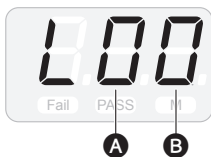

**A** 1 million torque-ups

**B** 0.1 million torque-ups

## <Inactive Time of Torque-up>

---

This is used to set the time during which re-torque-up (confirming fastening, re-fastening, etc.) just after torque-up is not to be detected as an error. During inactive time, the positive rotation data of the device is not sent.



### Setup value

0.0 to **0.5** to 9.9 seconds

# Connecting the Special Cable (Option)

If you connect an optional special cable to this device, you can transmit / receive data to / from the peripheral devices including PCs, PLCs etc.

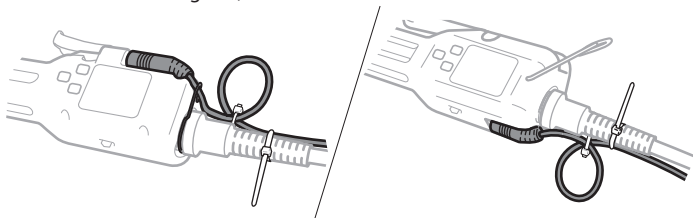

## Caution

If <Counter> is set inactive, no data is sent. Confirm it is active before you start communication with external devices. For details, refer to "Setting Menu List" (P. 23).

## Checking Supplied the Cable Accessories

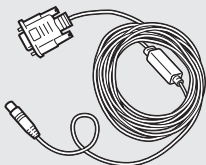

### Specifications of Special Cable

- Straight
- Total length: 3 m
- D-Sub 9 pin / female
- Straight plug (one-touch) 6 pcs



Clasp to hold the cable  
(for BLG-4000BC2/BLG-5000BC2 Series)



Cable tie 10 pcs

## Connecting to Screwdriver (BLG-4000BC2/BLG-5000BC2 Series)

### 1 If necessary, remove the screwdriver cord from the screwdriver.

- Turn off the power before removing the cord.

### 2 Tilt the hanger.

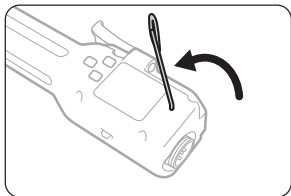

### 3 Connect the special cable to the I/O port.

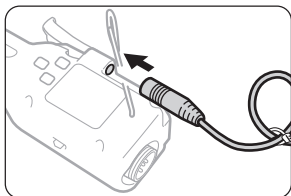

### 4 Attach the clasp for holding to the connector.

- Use the hook of the clasp to catch the cable and fit the clasp into the recess of the connector.

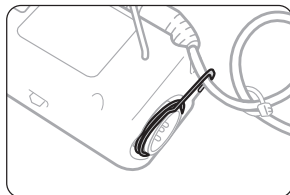
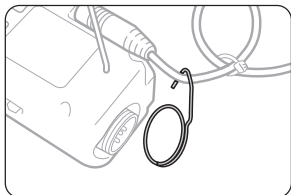

- Confirm that the direction of the clasp is correct.

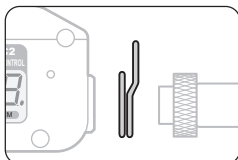

## 5 Connect the screwdriver cord.

- Use the joint ring to fix the cord.

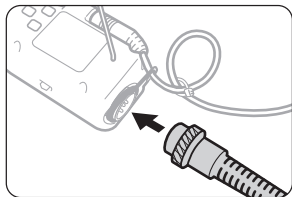

## 6 Use the cable tie to fix the special cable and the screwdriver cord.

- Fix the special cable so that it does not move.
- Fix it at a few points along the screwdriver cord.

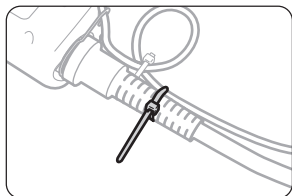

### Caution

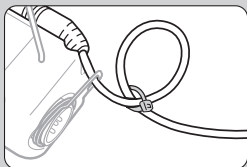

### A Loop to Avoid Excessive Load

A loop of the cable is made by a cable tie so that it has some looseness. Do not fix it too tight.

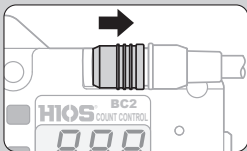

### How to Remove BLG-BC2-3012 Cable

Do not pull the cable too hard to disconnect it. Otherwise, it may cause a failure.

You can disconnect it by sliding the locked part of the plug.

## Connecting to Screwdriver (BLG-7000BC2)

### 1 How to connect to screwdriver

### 2 Connect the special cable to the I/O port.

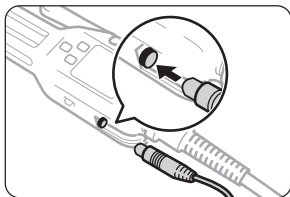

### 3 Use the cable tie to fix the special cable and the screwdriver cord.

- Fix the special cable so that it does not move.
- Fix it at few points along the screwdriver cord.

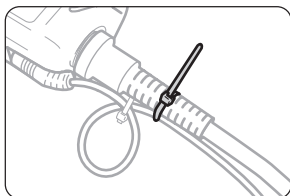

#### Caution

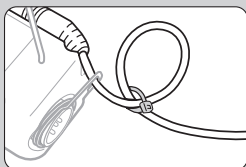

#### A Loop to Avoid Excessive Load

A loop of the cable is made by a cable tie so that it has some looseness. Do not fix it too tight.

#### How to Remove BLG-BC2-3012 Cable

Do not pull the cable too hard to disconnect it. Otherwise, it may cause a failure.

You can disconnect it by sliding the locked part of the plug.

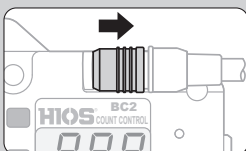

# Saving Screw Fastening Data

The CD-ROM supplied with the special cable contains a tool for saving screw fastening data obtained when using this device. The data is saved in CSV format. By using the tool you can also save the setting data on a PC, check operations or send / receive communication commands. If the CD-ROM is not included, please download it from our website.

## System Requirements

- Microsoft Windows 7 or later versions
- Up to four screwdrivers can be connected at once

## Screen of Connection

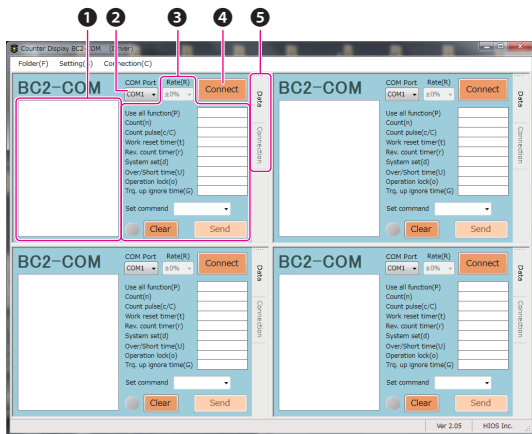

### 1 Log window

The operating status of the screwdriver and messages are displayed here.

### 2 COM port menu

Select the port number to which the screwdriver is connected.

### 3 Setup item

You can change the settings of the screwdriver.

### 4 Connect button

You can connect / disconnect the screwdriver.

### 5 Screen button

You can switch the screen between operation monitor and connection. For details of the operation monitor, refer to "Work Monitor" (P. 35).

## Connecting to Screwdriver

**1** Activate [Counter\_BC2\_Ch4\_Normal\_Ver2.05.exe].

**2** Select [Save\_Folder] in the [Folder] menu to decide where to save the data.

- The file path is displayed.

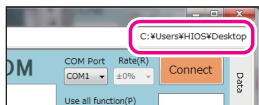

- The data are saved for each date.

**3** In the pull-down menu, select the port number to which the screwdriver is connected.

- You can see the port numbers in the [device manager] of Windows.

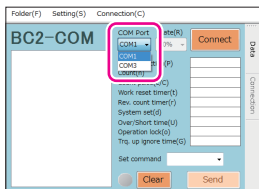

**4** Click [Connect].

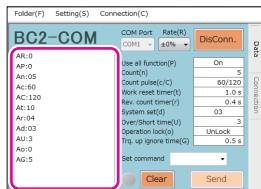
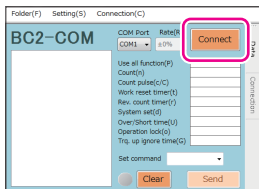

- The set values of the screwdriver are displayed in the log window.
- If you start up the device and find the date is changed, the data is saved on that date when connected.

## How to Read Output Data

You can review the operational status of the screwdriver and the pass / fail result in the log displayed in the log window on a real time basis. For details of the messages and commands, refer to "Communication Command / List of Messages" (P. 39).

L:1	Start the screwdriver
Pulse:008	The number of pulses in operation
Pulse:017	
Pulse:026	
Pulse:035	
Pulse:044	
Pulse:053	
Pulse:062	
Pulse:071	
Pulse:079	Torque-up
Pulse:088	The number of fastened screws and the last number of pulses at judgment
T	Judgment result
D:0003,088	
PASS	
L:0	Stop of the screwdriver

## Sending Command

If you click on an item, the command is set in Set command field. Enter a value / a number there and click [Send] button, the set value / number is sent to the screwdriver. The command is saved in the screwdriver.

For details of commands, refer to "Communication Command / List of Messages" (P. 39).

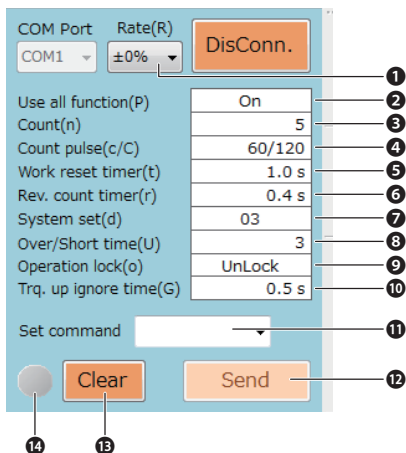

### ❶ Allowable range (Rate (R))

This specifies the allowable range to the pass / fail criteria.

### ❷ <Counter>

You can set whether to use all of the functions including pulse counting, screw counter, etc. If [Off] is set, no data is sent.

### ❸ <Screw counter>

Here you set the number of screws to be fastened.

### ❹ <Minimum pulse> / <Maximum pulse>

Here you set the upper threshold for pass / fail of screw fastening.

### ❺ <Work reset timer>

Here you set the length of the buzzer when the number of screws set by <Screw counter> is completed.

In addition, a reverse operation within the specified time cancels the count down when the set number of screws is completed.

### ❻ <Count timer for reverse rotation>

When the reverse counting time of <System> is active, here you specify the operation time before you can cancel the last count down.

If you perform a reverse operation of the device longer than the set time, the number of fastened screws of the last count down is to be counted up.

### ❼ <System>

This is used to set whether or not to use the buzzer sound for button operation and to use reverse counting.

This has no effect on the buzzer sound during direct teaching or of <Fail> judgment.

### ❽ <Pulse detection>

This is used to set whether to detect an error of <Minimum pulse> or <Maximum pulse> in the judgment of pass / fail.

### ❾ <Operation panel>

This is used to set whether to enable buttons on the operation panel.

### ❿ <Inactive time of torque-up>

This is used to set the time during which re-torque-up (confirming fastening, re-fastening, etc.) just after torque-up is not to be detected as an error. During inactive times, the positive rotation data is not sent.

### ⓫ Set command field

Enter a command.

### ⓬ [Send] button

The command is sent to the screwdriver.

### ⓭ [Clear] button

The log displayed in the log window is deleted.

#### 14 Unlock button

The screwdriver will be locked, and the button will be on when the total torque-ups reaches 1 million. It is unlocked with a click.

## Work Monitor

You can review the operational status of the screwdriver on a real time basis.

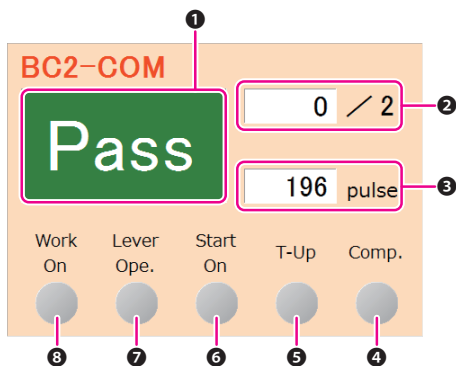

#### 1 Pass / Fail

The result of pass / fail is displayed. When no workpiece is detected, [Err] is displayed.

#### 2 Number of screws to be fastened

The set number of screws to be fastened and the number already fastened are displayed.

#### 3 Number of pulses

The number of pulses from start to stop of the screwdriver is displayed.

#### 4 Comp. indicator

It turns on (500 ms) when the set number of screws to be fastened is reached.

#### 5 T-Up indicator

It turns on (500 ms) when torque-up is confirmed.

#### 6 Start On indicator

It turns on when you start the screwdriver.

#### 7 Lever Ope. indicator

"x" is displayed when the switch lever is not enabled.

#### 8 Work On indicator

"x" is displayed when the message of no detection is received if workpiece detection is selected.

## Screen of Administration

Select this screen in the menu of [Setting] of Connection screen to control set values of the screwdriver from the PC. For each screw fastening term, you send a file after reading it or save the changes.

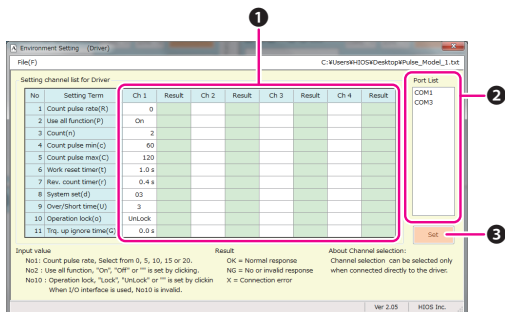

### 1 Setting channels

You can control up to four patterns at the same time.

### 2 Port list

Select the port to send the setting.

### 3 Set button

The setting is sent to the port selected in the port list.

## How to save setting

### 1 Click the [Setting] menu.

- The connection with the screwdriver is cancelled.

### 2 Change the setting item if necessary.

- The items are the same as those on the setting screen. For the details, refer to "Sending Command" (P. 33).

### 3 Select [Save As] in the [File] menu to decide where to save the data.

- The file path for the setting data is remembered.
- 4 patterns are saved in a file. If you want to save 5 or more patterns, create another file name.



## Specifications of Communication by Special Cable

- Pin numbers

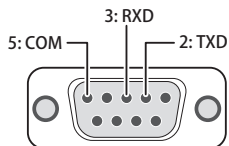

- Data transmission speed: 38,400 bps
- Data bit: 8 bits
- Stop bit: 1 bit
- Parity: none
- Communication format: ASCII

## Message Format

The message format has two types: setting command and inquiry command.

### Format for Setting Command

Example: You want to change the number of screws to be fastened to 3:

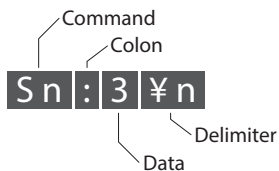

### Format for Inquiry Command

Example: You want to review the set number of screws to be fastened:

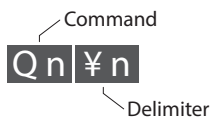

## Communication Command / List of Messages

When communication with the screwdriver is established, the following settings saved in the screwdriver will be sent.

AR, AP, An, Ac, AC, At, Ar, Ad, AU, Ao, AG

No.	Function	Setting change command	Message from screwdriver	Details	Command to confirm the set value of screwdriver
1	Whether or not to use all of the functions	SP:x	AP:x	To set whether to use all of the functions. 0: Enable 1: Disable (no data output)	QP
2	Screw counter	Sn:x	An:x	To set the number of screws to be fastened. x=1 to 99	Qn
3	Minimum pulse	Sc:x	Ac:x	To set any lower threshold for pass / fail x=1 to 999	Qc
4	Maximum pulse	SC:x	AC:x	To set any upper threshold for pass / fail x=1 to 999	QC
5	Work reset timer	St:x	At:x	To set the length of the buzzer when the number of screws set by <Screw Counter> is completed, and the reception time for cancellation of the final count down by reverse rotation. x=00 to 39 (0.0 to 3.9 seconds) ● The response message does not contain the decimal point.	Qt
6	Count timer for reverse rotation	Sr:x	Ar:x	To set the operation time before you can cancel the last count down. If you perform reverse operation of the device longer than the set time, the number of fastened screws of the last count down is to be counted up. x=01 to 10 (0.1 to 1.0seconds) ● The response message does not contain the decimal point.	Qr

No.	Function	Setting change command	Message from screwdriver	Details	Command to confirm the set value of screwdriver
7	System	Sd:xy	Ad:xy	<p>To set whether to use the buzzer sound and reverse counting.</p> <p>x=0 to 3</p> <p>0: Buzzer: active / reverse counting: active</p> <p>1: Buzzer: active / reverse counting: inactive</p> <p>2: Buzzer: inactive / reverse counting: active</p> <p>3: Buzzer: inactive / reverse counting: inactive</p> <p>y=2 to 3</p> <p>2: Buzzer for torque-up: inactive</p> <p>3: Buzzer for torque-up: active</p>	Qd
8	Whether or not to enable error detection	SU:x	AU:x	<p>To set whether to detect the upper &amp; lower thresholds for pass / fail of screw fastening.</p> <p>x=0 to 3</p> <p>0: Both thresholds: no detection</p> <p>1: Detect only the lower threshold</p> <p>2: Detect only the upper threshold</p> <p>3: Detect both thresholds</p>	QU
9	Operation panel button	So:x	Ao:x	<p>To set whether or not to enable buttons on the operation panel.</p> <p>0: Enable</p> <p>1: Disable (M indicator turns on)</p>	Qo
10	Inactive time of torque-up	SG:x	AG:x	<p>To set the inactive time of pass / fail judgment after torque-up. No signal is to be sent while it is inactive.</p> <p>x=0 to 99 (unit: 100 ms)</p>	QG
11	Request for transmission of set value	—	AR/AP/An/ Ac/AC/At/Ar/ Ad/AU/Ao/ AG	<p>The set values of No.1 to No.10 and No.15 will be sent at the same time. The same command is sent when you start up the screwdriver.</p>	QS

No.	Function	Setting change command	Message from screwdriver	Details	Command to confirm the set value of screwdriver
12	Switch lever operation	Lv:x	Lv:x	To set whether or not to enable the switch lever operation. 0: Enable 1: Disable (OFF is on the display)	—
13	Detection of workpiece	W:x	W:x	0: Disable (OFF is on the display) 1: Enable	—
14	Teaching factor message	—	AR:d Ac:x AC:x	This is sent when the allowable range to the pass / fail criteria is changed. d=0/5/10/15/20% x=1 to 999 (pulses)	—
15	Screwdriver operation message	—	L:x	You can review the operational status of the screwdriver. 0: Stop of the screwdriver 1: Start of the screwdriver	—
16	Pulse count message	—	Pulse:nnn	The number of pulses in operation (n) is sent with a constant interval. In case over 1000 pulses, **** is displayed.	—
17	Torque-up message	—	T	This is sent when a screw is seated.	—
18	Message of fastening is normal	—	D:x,Number of pulses	This is sent when judged as <PASS>. x=the number of screws to be fastened In case of over 1000 pulses, **** is displayed.	—
19	Pass message	—	PASS	Judgment: Pass	—
20	Message of fastening is error	—	E: ,Number of pulses	This is sent when judged as <Fail>. In case over 1000 pulses, **** is displayed.	—
21	Fail message	—	FAIL	Judgment: Fail	—
22	Count reset message	—	R	This is sent when the number of screws to be fastened is changed.	—

No.	Function	Setting change command	Message from screwdriver	Details	Command to confirm the set value of screwdriver
23	Message of reverse counting up	—	Rx,Number of pulses	This is sent when reverse operation is done if the reverse counting is active. x=the number of screws to be fastened In case of over 1000 pulses, **** is displayed.	—
24	Work off error message		W:Err	This is sent when no workpiece is detected in screw fastening.	—
25	Error reset	R:E		This is to release the workpiece off error in screw fastening.	—
26	Message of total number of fastening being reached	—	Over	The screwdriver will be locked by this message when the total number of fastening is over one million. Overhaul or maintenance is required.	—
27	Message of unlocking after locking	SL		This unlocks the screwdriver temporarily after it is locked because of the total number of fastening is over one million.	—
28	Total number of torque-ups	—	AL:x	You can review the total torque-ups. x=Total number	QL
29	Message of invalid command	—	CE:****	This is a responding message when an invalid command is received. ****=Invalid command string	—
30	Forced counter reset	R:C		This forcibly resets the number of screws to be fastened.	—
31	Review of the device version	—	Ver x.xx BC2 Pulse yyyy/ mm/dd	x.xx=version of the device	QV

# Troubleshooting

If you encounter any problems, please check the solution in this section before making an inquiry. If the problem persists, please contact your dealer or our service department.

## Common Problems

Symptoms	Action
The bit comes out or you cannot attach the bit.	<ul style="list-style-type: none"><li>● Check if you used the bit appropriate to the model. Also refer to "Attaching a Bit" (P. 07) to see if you attached it correctly.</li></ul>
The torque is too small to fasten a screw sufficiently.	<ul style="list-style-type: none"><li>● Check if you used a genuine HIOS product and if you used the specified torque adjustment spring.</li><li>● Adjust the torque by referring to "Reference table of output torque".</li></ul>
The screwdriver does not start rotation.	<ul style="list-style-type: none"><li>● Check if power is supplied. If power is supplied and the device does not start, turn off the power once and check if the cord is connected correctly. Then, turn on power again.</li><li>● Check if the FOR/REV switch is not at 0.</li></ul>
The number of pulses has an error	It happens when you use positive rotation just after reverse rotation. To eliminate the error, you need to do some temporary fastening before you keep on working.
No data come out The data is garbled.	<ul style="list-style-type: none"><li>● Turn off the power and check if the special cable is connected correctly. Then, turn on the power again.</li><li>● Check if it is connected correctly by sending an inquiry command such as [QS].</li></ul>

## When the Messages Below Are Displayed

---



- When the total fastening exceeds one million, this message will be displayed, and the screwdriver will be locked. In that case, overhaul or maintenance is required. Please contact your dealer or our service department.  
If you want to unlock it temporarily, press and hold the F2 and F3 buttons at the same time.

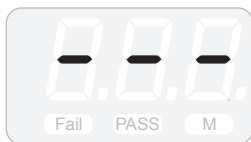

- This message will be displayed when the pulse exceeds 1000 after starting the screwdriver.



- The <Minimum Pulse> and the <Maximum Pulse> are wrongly placed in the reference values. If you want to manually enter the number of pulses, set the tolerance factor to 0%.

## Want to See the Device Version

---

- Follow the procedure below: press and hold the F1 button; press the F3 button to set it <OFF>; then, press and hold F1 button.



### Caution

If you set it <OFF>, you can no longer use all of the functions. If you use the counter, set it back to <On>.

# Maintenance

We determined the guarantee period by assuming the screwdriver is used 8 hours a day.

We recommend periodic overhaul inspection once a year. After sales services.

## About BLG-7000BC2-GT

---

Check that tarret and handle are firmly fastened on a regular basis. If it is loose, fasten it with specified torque again.

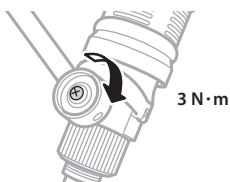
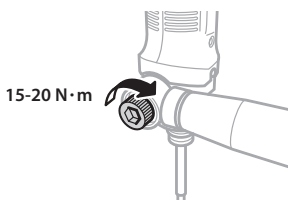

# Specifications

The device specifications are subject to change without prior notice due to improvements of the device.

## BLG-4000BC2 Series

Unit [mm]

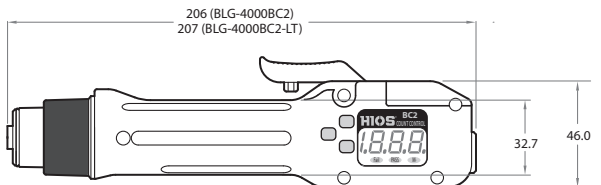

Model		BLG-4000BC2	BLG-4000BC2-LT
Output Torque Range (N·m)		0.1 to 0.55	0.03 to 0.2
Unloaded Rotation Speed (r.p.m) ±10%	HI	1,000	1,000
	LOW	690	690
Screw Size (mm)	Machine Screw	1.4 to 2.6	1.0 to 2.3
	Tapping Screw	1.4 to 2.3	1.0 to 2.0
Bit Drive	Standard	H4	
	Option	1/4HEX	-
Weight (g)		Approx. 370	Approx. 312
Controller	BLC-45	●	●
	BLC-70	●	●
	BLC-80	●	●

## BLG-5000BC2 Series

Unit [mm]

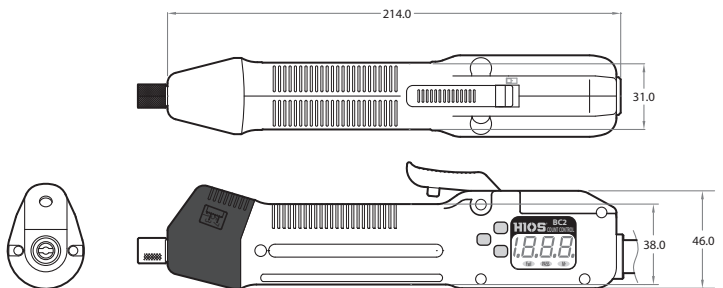

Model		BLG-5000BC2	BLG-5000BC2-15	BLG-5000BC2-18	BLG-5000BC2-HT
Output Torque Range (N·m)		0.2 to 1.2	0.3 to 1.0	0.5 to 1.5	0.5 to 2.0
Unloaded Rotation Speed (r.p.m) ±10%	HI	1,000	1,500	1,800	730
	LOW	690	1,000	1,200	—
Screw Size (mm)	Machine Screw	2.0 to 3.0	2.3 to 3.0	2.3 to 3.0	2.0 to 4.0
	Tapping Screw	2.0 to 3.0	2.0 to 2.6	2.0 to 2.6	2.0 to 3.0
Bit Drive	Standard	H4		H5 and 5HEX	
	Option	•H5 and 5HEX •1/4HEX		1/4HEX	
Weight (g)		Approx. 425			
Controller	BLC-45	●	●*	—	●*
	BLC-70	●	●*	●*	●*
	BLC-80	●	●*	●*	●*

\*Set the voltage output switch to HI for use. If set to LOW, the screwdriver's unique performance may not be fully exhibited.

## BLG-7000BC2

Unit [mm]

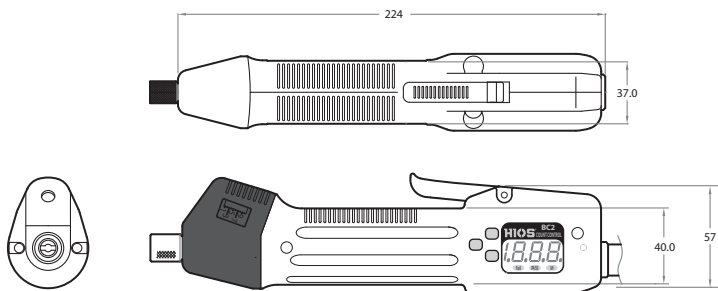

Model		BLG-7000BC2
Output Torque Range (N·m)		0.7 to 2.8
Unloaded Rotation Speed (r.p.m) ±10%	HI	1,200
	LOW	800
Screw Size (mm)	Machine Screw	2.6 to 5.0
	Tapping Screw	2.6 to 4.0
Bit Drive	Standard	H5 and 5HEX
	Option	1/4HEX
Weight (g)		Approx. 670
Controller	BLC-45	—
	BLC-70	●*
	BLC-80	●*

\*Set the voltage output switch to HI for use.

If set to LOW, the screwdriver's unique performance may not be fully exhibited.

## BLG-7000BC2-GT

Unit [mm]

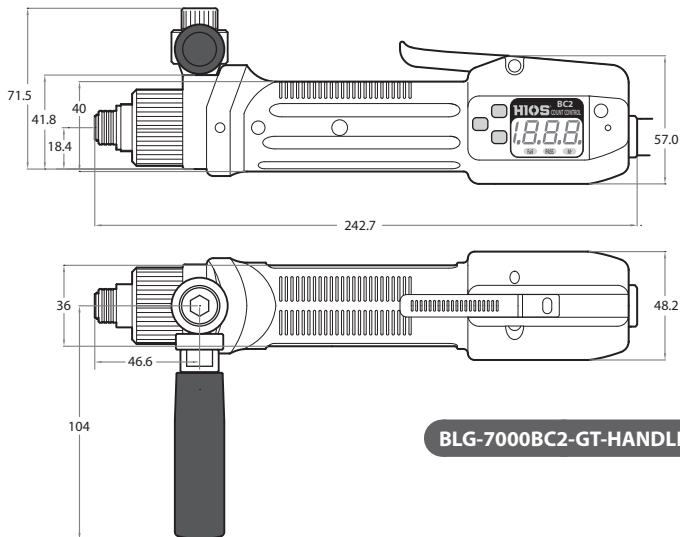

BLG-7000BC2-GT-HANDLE

Model	BLG-7000BC2-GT-S BLG-7000BC2-GT-HANDLE	
Output Torque Range (N·m)	2.0 to 5.0	
Unloaded Rotation Speed (r.p.m) ±10%	HI	540
	LOW	-
Screw Size (mm)	Machine Screw	4.0 to 6.0
	Tapping Screw	4.0 to 6.0
Bit Drive	Standard	1/4HEX
Weight (g)	-HANDLE	Approx. 1,000
	-S	Approx. 1,915
Controller	BLC-45	-
	BLC-70	-
	BLC-80	●*

\*Set the voltage output switch to HI for use.

If set to LOW, the screwdriver's unique performance may not be fully exhibited.

## BLG-7000BC2-GT-S

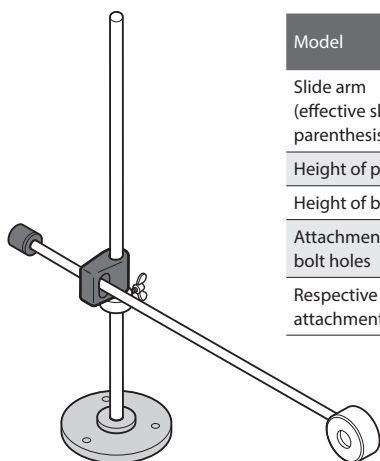
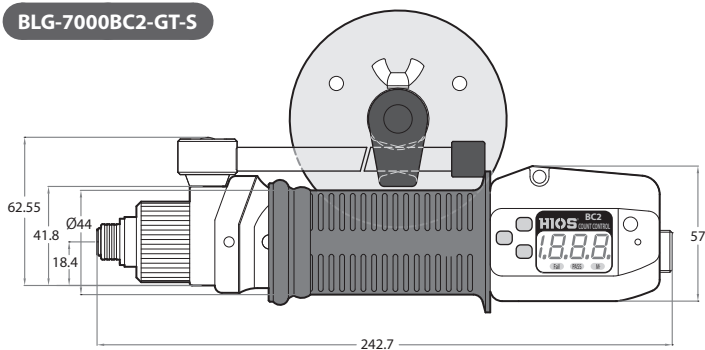

Model	Shockless Stand
Slide arm (effective sliding range in parenthesis)	530 mm (475 mm)
Height of pole	570 mm
Height of base	8 mm
Attachment bolts inner diameter of bolt holes	6 mm
Respective distances between attachment bolts	52 mm

# Notice

## Disclaimer

---

The information in this document is subject to change without notice.

## Trademarks

---

Microsoft, and Windows are either registered trademarks or trademarks of Microsoft Corporation in the United States and/or other countries.

All other product and brand names are registered trademarks, trademarks or service marks of their respective owners.

## Illustrations used in this manual

---

Illustrations used in this manual are those for BLG-4000BC2 and BLC-45 unless otherwise noted. However, if models have differences, multiple illustrations are also displayed with the model names such as "BLG-XXXX / BLG-XXXX".

**HIOS<sup>®</sup>**

**HIOS Inc.**

---

1-35-1 Oshiage, Sumida-ku Tokyo, Japan 131-0045

[www.hios.com](http://www.hios.com)