

■ Counter Display Section

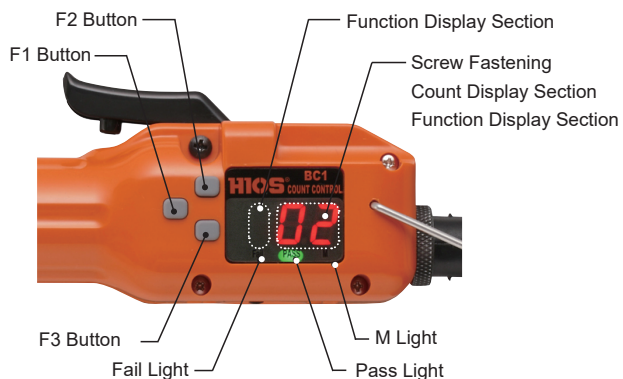

(1) Screw Fastening Count Display Section/Set Value Display Section

- In the normal mode, the screw fastening count set value is displayed first, and after starting the count, the remaining screw fastening count is displayed.
- The count decreases with each screw fastening operation and the remaining screw fastening count is displayed.

(2) Function Display Section

- The symbol corresponding to the set item is displayed in the setting mode.

(3) F1 Button

- When this button is pressed for more than 2 second in the normal mode, the mode is changed to the setting mode.
- This button is used for selecting the function in the setting mode.
- When this button is pressed for more than 2 second in the setting mode, the buzzer sounds twice and the mode is changed to the normal mode.

(4) F2, F3 Button

- Using these buttons, the set value can be changed in the function setting.
- Some set values are limited depending on the function to be set.

(5) Pass Light*

- When the screw fastening result is "OK", the green LED light turns ON.

(6) Fail Light*

- When the screw fastening result is "NG", the red LED light turns ON.

* If you run the driver, the pass of Fail OFF.

■ Other Operations

The count is to be returned to the default value during the screw fastening operation.	Pressing the F3 Button for 2 seconds or more, resets the screw fastening count value.
How to check the Counter Timer Set Time.	When the screw is fastened for the time period (second) set using the counter timer: <ul style="list-style-type: none"> ● For correct operation, the buzzer sounds once. ● For incorrect operation, the buzzer does not sound. When the buzzer does not sound, increases the set value gradually and adjusts it so that the buzzer sounds once. The confirmation with the buzzer sound is useful for preventing a screw fastening error.
Lock F Buttons.	<ol style="list-style-type: none"> 1. Slide the FOR/REV switch to FOR. 2. Idle for about 20 seconds. → "M" light is turned on, and the buttons are locked. They will be unlocked if you redo the above steps.

■ Precautions in the Unit Operation

- When the output setting for Power HI/LOW is changed, the driver speed changes. In such cases, pay attention to the counter timer set value and reverse counter timer set value.
- Appropriate operation environment.
 - Do not use the unit in an environment where the ambient temperature is outside the range of +5 to 40 °C.
 - In an area with static electricity, use this unit only after removing the static electricity.

HIOS®

Brushless® Screwdriver

with built-in Screw Counter

BLG-BC1 Series

INSTRUCTION MANUAL

(October 2023)

No.ET-A011-BC1 23A

■ Features

- OPC (output signals) is available.
 - When the driver is connected to the HIOS relay box "BLOP-AF", an external device such as a sequencer, a revolving light or a buzzer can be used to visualize the screw fastening operation with the signals.
- This unit can be used also as a normal driver with the counting function cancelled. The display is also OFF.
- The driver, running without fastening the screw, or reverse turning, is not counted.
- Screw fastening errors can be detected with easy operation and setting.

HIOS Inc.

1-35-1 Oshiage, Sumida-ku Tokyo, Japan 131-0045

TEL: +81-3-6661-8821

■ Setting Function List

Display	Setting Function <Default Value>	Symbol	Setting Description
(1)	Counter ON/OFF Setting <0n>	P	0n : When selected, the counter function is available. OFF : When selected, it is used as a normal driver. The display is also OFF.
(2)	Count <n05>	n	The screw fastening count value is set. Setting Range : 1 to 99
(3)	Count Timer <c.30>	C	This function is used to prevent the count for double tightening operations such as check fastening or retightening. Set the operation time while the check fastening is performed for the tightened screw. Setting Range : 0.00 to 0.99 seconds Note: When the screw tightening operation is performed during setting and the judgment result is normal, the buzzer sounds once.
(4)	Work Reset Timer <t 1.0>	t	The buzzer sound time period after the work is completed is set. Setting Range: 0.0 to 3.9 seconds Note: Set it based on the reverse count timer set value.
(5)	Reverse Count Timer <r.0.4>	r	The time period until the reverse count is performed is set. Set the work reset timer operation time based on the time period up to when the reverse count is performed. Setting Range: 0.1 to 1.0 seconds Note: It is available when the "Reverse Count Enable" has been set in the system setting.
(6)	System Setting <d03>	d	Each Buzzer or Reverse Count Enable/Disable is set up. The setting is performed with a combination of the tens digit and single unit digit. Tens Digit 0 : Buzzer Enable/Reverse Count Enable 1 : Buzzer Enable/Reverse Count Disable 2 : Buzzer Disable/Reverse Count Enable 3 : Buzzer Disable/Reverse Count Disable Units Digit 2 : Torque Up Buzzer Disable 3 : Torque Up Buzzer Enable
(7)	Over Time / Short Time <U 3>	U	This sets whether or not the Over Time/Short Time error is detected. 0 : When selected, neither Over Time or Short Time Error is detected. 1 : When selected, only the Short Time Error is detected. 2 : When selected, only the Over Time Error is detected. 3 : When selected, the both Over Time/Short Time Error are detected.

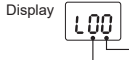
Display	Setting Function <Default Value>	Symbol	Setting Description
(8)	Accumulated Counter <L00>	L	The accumulated count of the screw fastening operation is displayed. For the accumulated count, all the torque-up operations are counted regardless of whether the counter is ON/OFF. Display  How to read the display Units Digit: Numbered in multiples of 100,000 shots Tens Digit: Numbered in millions of shots

■ Operation

Changing to the Setting Mode

Press the F1 Button for more than 2 seconds in the normal mode. "P" will be displayed in the function display section and the mode will be changed to the setting mode.



Setting Mode

Each pressing of the F1 Button in the setting mode changes the setting item. Refer to "Setting Function List" for the setting function details.

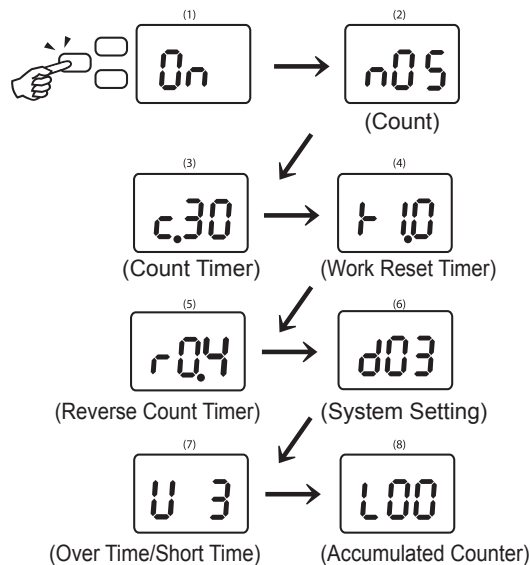

Changing to the Normal Mode

Press the F1 Button for more than 2 seconds in the setting mode. The mode will be changed to the normal mode and the value set for the count will be displayed.



● Counter ON/OFF Setting

Each pressing of the F3 Button toggles ON and OFF. (Note: F2 Button is not to be used.)

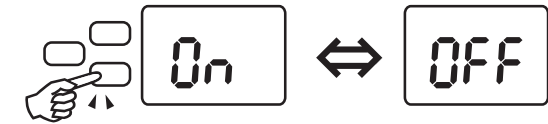

● Value Setting for Each Function

1. Each pressing of the F2 Button in the setting mode changes the figure position for setting.



2. Each pressing of the F3 Button increases the value one by one.

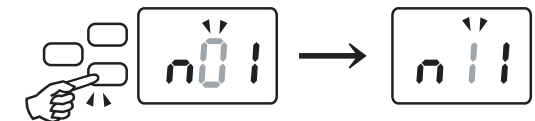

Note :The setting procedure is the same for all the settings except for the "Counter ON/OFF Setting". Refer to "■ Setting Function List" for the setting range.