



Impact Torque Meters

HIT-Series

HIT-200

HIT-500

HIT-2000

Owner's Manual
(November 2021)

HIOS Inc.

1-35-1 Oshiage, Sumida-ku Tokyo, Japan 131-0045

TEL: 81 (Japan) 3-6661-8821

FAX: 81 (Japan) 3-6661-8828

■ Introduction

HIT Digital Torque Meters directly measure torque of impact drivers, pneumatic drivers, clutch-type torque wrenches, etc. Its first peak circuit gives high accuracy of torque of impact drivers. Battery powered and easily brought to the assembly line or work place, you will find it extremely handy to use. It can be connected to a printer for greater usefulness in quality control. A must for safety control of bolts and nuts.

■ Features

- Rechargeable instrument for measuring the torque of impact drivers, pneumatic drivers and torque wrenches.
- Audible signal can be set to sound at desired torque level in peak and first peak modes.
- The only instrument you need for measuring N•m, kgf•cm and lbf•in.
- Digital display eliminates readout errors.
- Measures in either direction.
- Has printer and analog output terminals.
- Compact, light and rechargeable, for ease of portability.

■ Parts

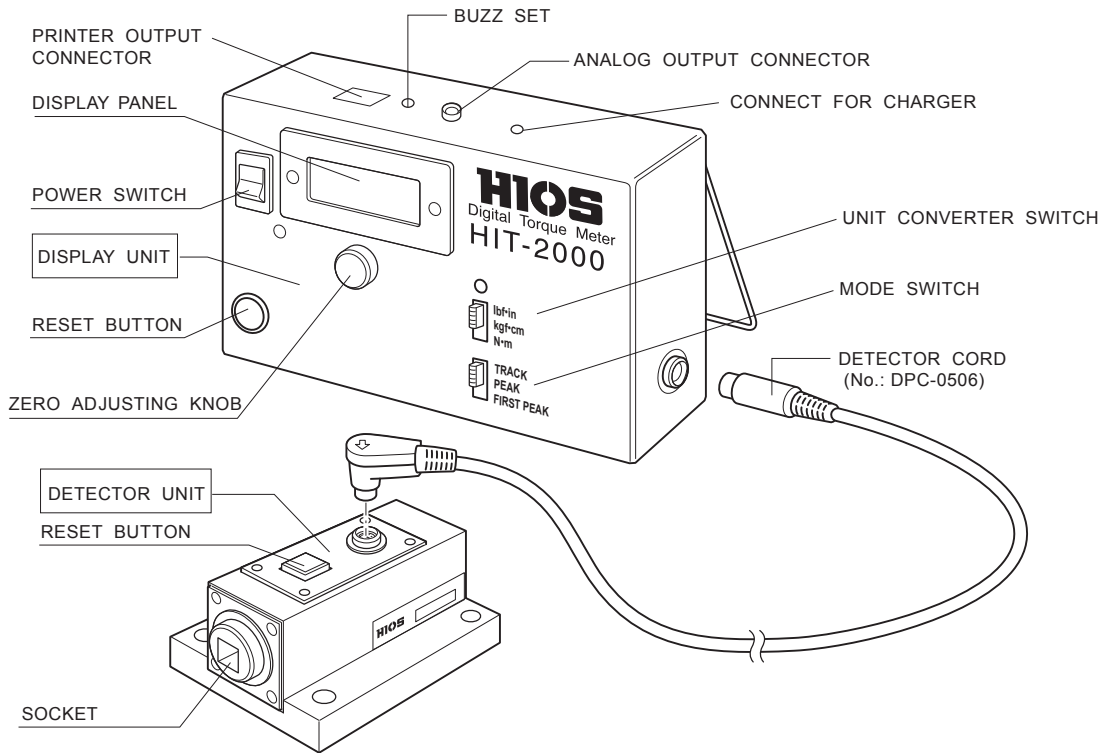

● Printer output connector

The meter performs recording of data, structuring them into statistics, compute processing and also can be connected to personal computers, thus can be developed to high quality information processing system. This system is called SPC (Statistical Process Control).

● Unit converter switch

lb·in ↔ kgf·cm ↔ N·m

● Mode switch

PEAK Holds load value (clear with reset button).

TRACK Display changes according to load (cleared by removing load).

FIRST PEAK Measures first peak and gives an audible signal when first peak is reached (Requires a differential of at least 5.0 kgf.cm).

● Socket

This socket is for attaching the device to be measured.

● Buzz set

The buzz set function informs users of arrival at a desired torque with a buzz.

■ Operation

First check the battery level!

Turn the power switch on. If the charge is inadequate, the message "LOBAT" will be displayed. In that case, recharge the battery for about 3 hours. Never recharge for more than 8 hours.

1. Bolt the detector unit to the work bench.
2. Set unit converter switch to the desired measurement unit.
3. Set mode switch to the desired measurement mode and use the zero adjusting knob to adjust the displayed value to zero.
4. Conducting measurement

- Track measurement:

Set mode switch to "Track." Changing torque values will be displayed according to the load to the detector unit. Display returns to zero when the load is removed.

- Peak measurement:

When peak measurement is desired, set the Mode Switch at PEAK. The peak value is held for more than 5 seconds when more than 15 digits signals are inputted. It can be cancelled by pushing the reset button.

- First peak measurement:

Set mode switch "First peak." Use for measuring torque wrenches. Measures first peak values and gives an audible signal when first peak is reached.

* Use size 9.5 x 9.5 or 12.7 x 12.7 square sockets (commercially available), or make a socket adaptor for other sizes.

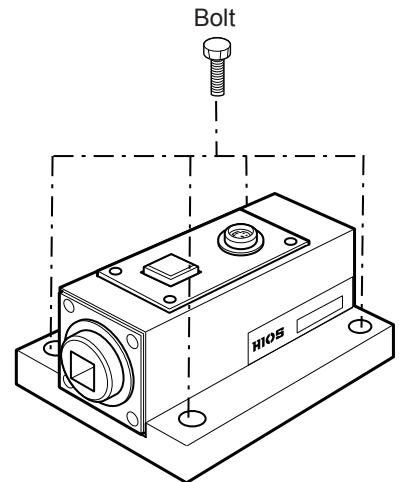

Measurement of impact drivers

- (1) Attach a 9.5 x 9.5 or 12.7 x 12.7 square socket adaptor to the detector unit socket.
- (2) Fit the driver into the adaptor and start the motor.
- (3) The peak load value will be displayed. Read off this value and push the reset button to cancel the value.
- (4) Repeat the above process as necessary.

Torque wrench measurement

- (1) Set mode switch to "FP."
- (2) Attach a 9.5 x 9.5 or 12.7 x 12.7 square socket adaptor to the detector unit socket.
- (3) Fit the wrench into the adaptor and start the motor.
- (4) You will hear a "click" when the first peak has been measured. The display freezes on this value. It does not change with changing load to the detector unit.
- (5) Read off this value, then push the reset button to cancel it.
- (6) Repeat the above process as necessary.

5. When using a printer set the mode switch to "Peak." When peak measurement is desired, set the Mode Switch at PEAK. The peak value is held for more than 5 seconds when more than 15 digits signals are inputted. It can be cancelled by pushing the reset button. (There are reset buttons on the display and the detector unit.)
6. See "Setting torque level signal tone" below to set the signal tone to sound when the desired torque level is reached.
7. When you are finished measuring, turn off the power switch and remove the driver, etc. from the socket.

■ How to set the buzz set

1. Turn the zero adjustment knob until the desired torque value is displayed.
2. Turning the buzz set volume control to the left causes the signal to sound, then stop turning.
3. Turn the zero adjustment knob until the displayed value reads zero. (Note that the set value is not displayed, so it may be helpful to make a written note of it.)
4. If the mode switch is set to track mode, the buzz will sound at the preset value. This can be turned off by removing the load to return the display to zero.
5. In peak measurement, when the preset load is reached, the buzz will stop and the value will freeze on the peak value. The display can be returned to zero by pressing the reset button.
6. To terminate the buzz set, turn the volume control all the way to the right. When not using the signal tone, keep the volume control set turned all the way to the right.

■ Recharging

Turn the power switch off before recharging, using the recharging unit. A full recharge takes less than 8 hours.

(Caution)

- Never recharge for more than 8 hours.
- Do not use the recharging unit for recharging anything but HIT Digital Torque Meters.
- Do not use the instrument during recharging.

■ Type of data output

Use the Mitutoyo Input Tool (available for purchase from many dealers) to transfer measurement data to a computer.

- Measured data input unit input tool (USB keyboard conversion type)
Model: No. IT-016U

* Uses Mitsutoyo Connection cable, No. 06AGF590 2 m (sold separately)

■ Analog output

This instrument can be connected to Pen recorders, Vidi-light recorder, Oscilloscopes, Voltmeters, etc. When using with these products, please refer to the appropriate operation manuals.

■ Inspection and calibration

The detecting element of the HIOS Digital Torque Meter has a specially designed structure and maintains its stabilized load accuracy over a long period of time. However at least once a year inspections are required to get the best use from the Meter. Calibration can be practiced by customers using a weight and weight hanging disk (optionally available) to be attached to the Joint Shaft while the Detector is horizontally held by a clamp. When a stabilized and correct state cannot be achieved by the customer, adjustment and repair will be carried out by local authorized distributors. When the jam is found exceeding local technical ability, the Meter will be repaired by the manufacturer.

■ Attention

The product that you have purchased contains a rechargeable battery. The battery is recyclable. At the end of its useful life, under various state and local laws, it may be illegal to dispose of this battery into the municipal waste stream.

Check with your local solid waste officials for details in your area for recycling options or proper disposal.



Ni-MH

■ Caution

- Never apply more torque than the tolerance level given in the specifications, as this could damage the instrument.
- Do not strike the plastic display panel or place heavy objects on it.
- Because torque meters are sensitive to ambient conditions, it is necessary to occasionally perform zero adjustment.
- Take care to shield the instrument from exposure to water, oil or other liquids, vibration, dust, hot air, indoor or outdoor electrical noise, high humidity (operating humidity range is 35-65%), temperature extremes (operating temperature range is 15°C - 40°C) and all other conditions that could harm the instrument or impair its functioning.
- Do not remove the back panel for calibration, etc.
- Refrain from rough usage or dropping of the instrument.
- Do not store in places subject to high humidity or extreme drops in humidity that could result in harmful condensation inside the instrument.

- Please note that the display and detector units of your HIT Digital Torque Meter each have the same serial number because they are calibrated together and are meant to be used together.

■ Outer view of detector unit

HIT-200

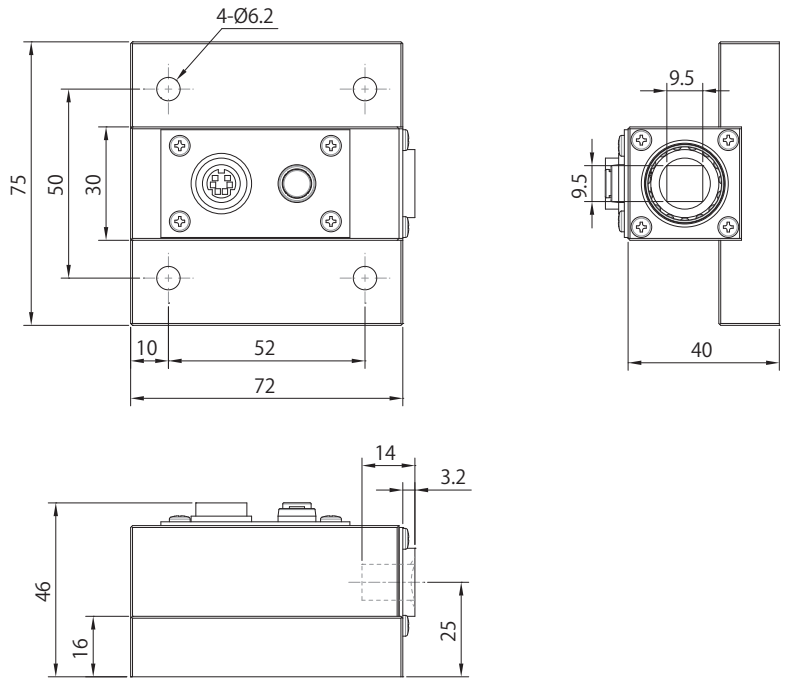

HIT-500
HIT-2000

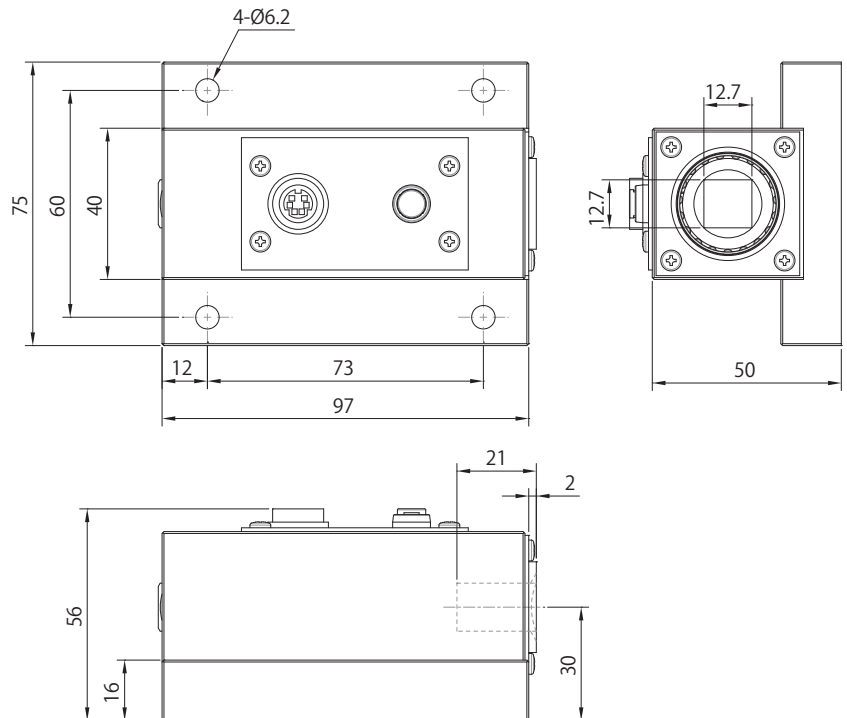

■ Specifications

Model No.		HIT-200	HIT-500	HIT-2000
Peak mode measuring range	N•m	0.15 - 18.00	1.5 - 50.0	25.0 - 180.0
	lbf•in	1.5 - 160.0	1.5 - 440	250 - 1600
	kgf•cm	1.5 - 180.0	15 - 500	250 - 1800
Accuracy		±1 % (+ 1 digit) F. S.		
Measuring mode		peak, track, first peak		
Dimensions of display (mm)		165 × 95 × 55 (H)		
Weight	Torque display	1.0 kg		
	Detector	0.85 kg	1.65 kg	
Inner socket diameter		9.5 × 9.5 mm	12.7 × 12.7 mm	
Detector cord		1.7 m (No. DPC-0506)		
Power source		6V NiMH* Recharge time is within 8 hours. Can be used continuously for up to 8 hours on a full charge.		
Battery life		Approx. 300 charges		
Exclusive charger		Input: AC 120V or 220 - 240V Output: DC 7.2V, 120mA		
Output terminals		Analog output: HIT-200 (2.4V Max.) HIT-500 (0.6V Max.) HIT-2000 (2.1V Max.) Numeric settings for signal tone		
Accessories		1 recharging unit. One 1.5-meter cord for analog output.		

Caution: Never apply a torque load on the instrument exceeding 120% of the tolerance level given in the specifications.

ANALOG OUTPUT SPECIFICATIONS

Load Impedance > 1 k Ω

1 digit \cong 1 mV

OUTPUT SPECIFICATIONS

1. Connector pin location

MITSUTOYO MQ65-5P

- ① GND
- ② DATA: data output in the format shown
- ③ CK: clock
- ④ GND
- ⑤ REQ: request for data output
- ①-④ : Open drain
-0.3 - +7V (400 μ A max.)
- ⑤ Pull up to V_{DD} (1.55V)

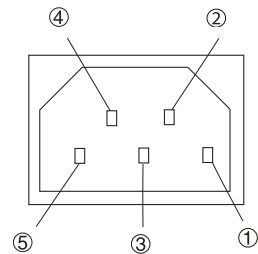

2. Data output format

Thirteen digits output in the sequence shown below.

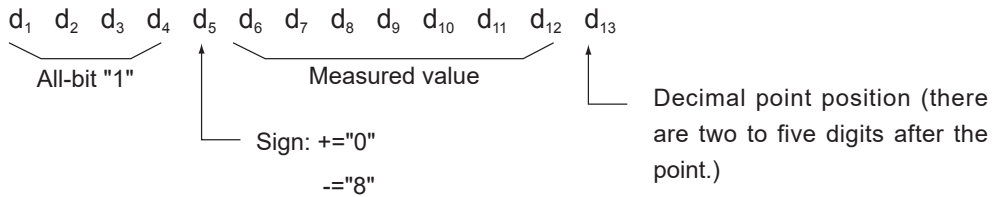

Each digit is output in four-bit binary notation from the LSB in the sequence $2^0 \rightarrow 2^1 \rightarrow 2^2 \rightarrow 2^3$.

3. Timing chart

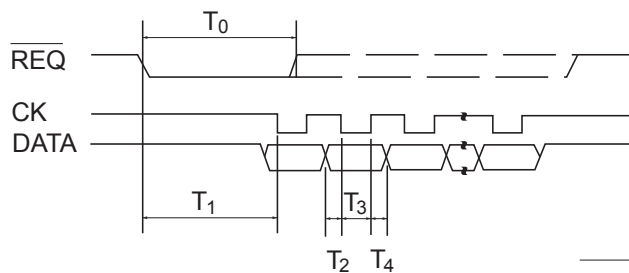

	MIN	MAX	UNIT
T ₀	2	—	sec
T ₁	0.2	0.4	sec
T ₂	0.2	0.4	mS
T ₃	0.5	1	mS
T ₄	0.2	0.4	mS

■ The following table is for CHINA RoHS2

If you are asked by China Customs, please show this table to them.

有害物质名称及含量标识格式						
产品中有害物质的名称及含量						
部件名称	有害物質					
	铅 (pb)	汞 (Hg)	镉 (Cd)	六价铬 (CR (VI))	多溴联苯 (PBB)	多溴二苯醚 (PBDE)
充电池	○	○	○	○	○	○
外壳	○	○	○	○	○	○
电源适配器	×	○	○	○	○	○
本表格依据 SJ/T 11364 的规定编制。 ○：表示该有害物质在该部件所有均质材料中的含量均在 GB/T 26572 规定的限量要求以下。 ×：表示该有害物质至少在该部件的某一均质材料中的含量超出 GB/T 26572 规定的限量要求。						

In addition, the China RoHS marks also is required at the product and product box.

At the product, you can find it at the bottom and it is marked on the product box.

If you cannot find the mark, please ask your distributor.

In case of emergency, please cut the mark below and stick at the bottom of product and on the product box.

China RoHS mark



