

Neji Taro II for Automatic Assembly HS-RB series

HS-35RB HS-40RB

HS-50RB

Instruction Manual

Read this manual before using this device.
Current as of October 2021



HIOS Inc.

1-35-1 Oshiage, Sumida-ku Tokyo, Japan 131-0045
TEL: +81-3-6661-8821 FAX: +81-3-6661-8828

CONTENTS

1. Before Use	2	6. Maintenance	14
2. Operating Precautions	2	7. Troubleshooting Guide	21
3. Component Names	4	8. Specifications	24
4. Pre-operational Checks and Adjustments	5	9. External dimension	26
5. Operating Procedures and Operational Checks	11	10. The following table is for China RoHS2.....	27

1. Before Use

Thank you for purchasing the Automatic Screw Feeder “Neji Taro II for Automatic Assembly Type”

Before using the Neji Taro II , make sure that the following accessories are supplied with the machine.

Accessories	*CD-ROM	1		
	*AC adapter	1 unit	*Hexagonal wrench key	1 set
	*Screwdriver	1 piece	*Ground wire	1 piece

To obtain optimum performance from the machine, it is essential that you thoroughly read this manual.

2. Operating Precautions

Installation site

 **CAUTION** Install the machine at a level, steady place.
If you install the machine in an unstable location, it may topple or fall, causing personal injury.

 **CAUTION** Do not operate the machine in places where a flammable or explosive gas exists or the humidity is high.
Using the machine in such places will create a safety hazard.

When shutting down the machine at day's end or leaving it unused for long periods of time

 **CAUTION** When shutting down the machine at day's end or leaving it unused for long periods of time, disconnect its AC adapter from the power outlet.

AC adapter

 **CAUTION** Use the accessory AC adapter only.

Rail

Do not scratch the rail. Do not apply any oil or grease to the rail.

Unusable screws

Use the specified screws only. Avoid using screws to which oil, grease, dirt, or other foreign matter is attached.

Screw removal precautions

When removing screws, exercise care not to apply any undue force or shock to them.

Avoid inserting foreign objects

 **CAUTION** Do not position your fingers or foreign objects in the screw bin, holes, or other open spaces because you may be injured.
Be sure that no inappropriate screws or foreign objects are allowed to enter the machine.

Abnormality during operation

 **CAUTION** If any abnormality occurs during operation, turn off the power switch and disconnect the AC adapter from the power outlet
If you continue to use the machine while it is acting abnormally, a risk of fire, electric shock, or personal injury may be caused. If you encounter any abnormality, contact your local dealer.

Avoid making and attempt to repair, disassemble, or modify the machine

 **CAUTION** When the machine is in need of repair, contact your local dealer.

the bottom of the main body



Attach the ground wire by loosening the screw near the mark  of the equipment.

3. Component Names

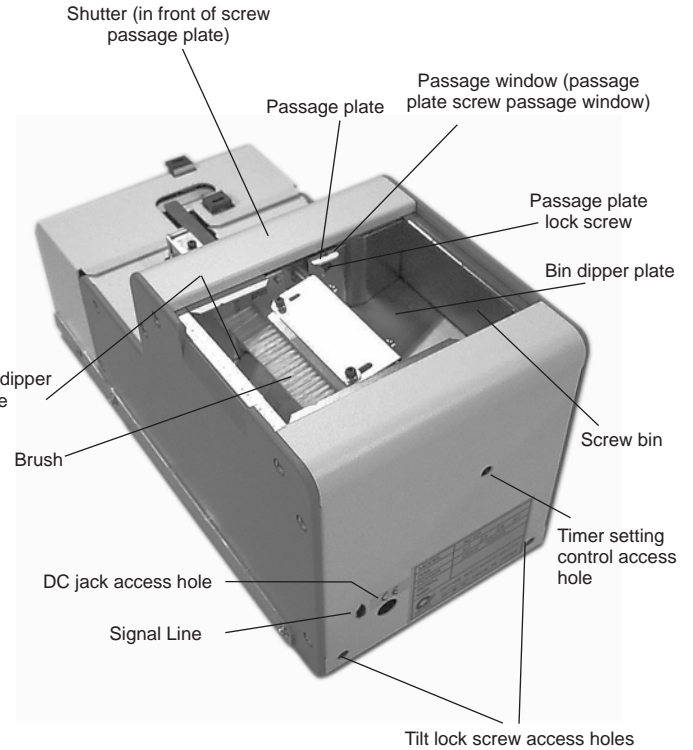
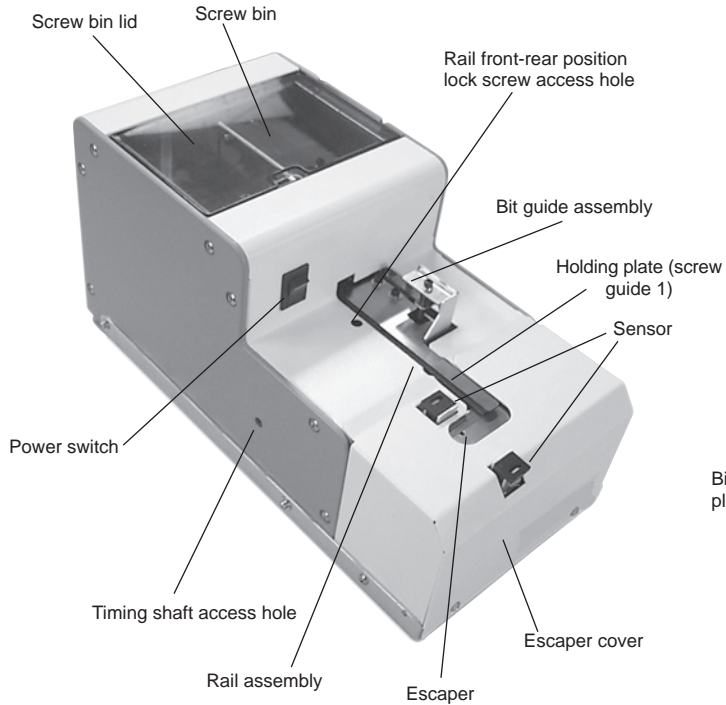

4. Pre-operational Checks and Adjustments

4-1. Confirming the Machine Model Number

Before using the machine, verify that the model matches the screw size to be used.

To confirm the model number, remove the escaper cover and note the labels attached to the rail assembly and escaper. The identification label marking is in R** form.

The machine can be converted to accept a different screw size by replacing the rail assembly, escaper, and passage plate. When you replace component parts, verify the employed screw size.

Model	Nominal screw diameter	Rail model No.	Passing plate model No.	Escaper guide of the robot model No.
HS-35RB	M3.5	HS-R35RB	HS2-01008-35	HS2RB-06506-40
HS-40RB	M4.0	HS-R40RB		
HS-50RB	M5.0	HS-R50RB	HS2-01008-50	HS2RB-06506-50

Note: You can change the model without changing the type. Replacement rails, escapers, and passage plates are available as options.

The machine is factory adjusted for pan-head screws prior to shipment. If readjustments are needed to match the employed screw, complete the following check/adjustment procedures before using the machine.

- Checking and adjusting the brush
- Checking and adjusting the holding plate (screw guide 1)
- Checking and adjusting the passing plate
- Checking and adjusting the rail assembly and escaper components

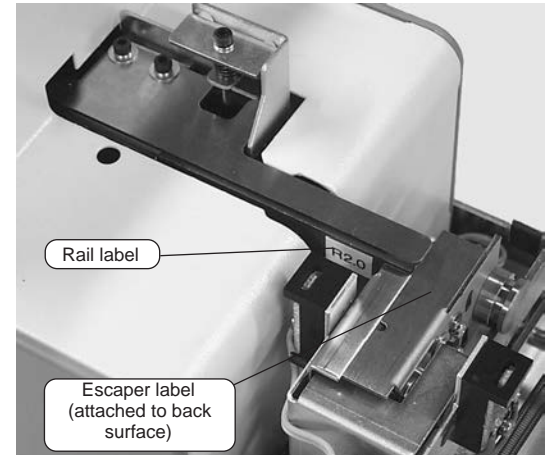



CAUTION

Before performing any check/adjustment procedure, turn off the power switch.

4-2. Checking and Adjusting the Brush

Check the height of the brush. Ensure that the brush check/adjustment procedure is completed while the brush is placed in a horizontal position as shown at right. To place the brush in a horizontal position, rotate the timing shaft with the accessory Allen wrench.

Have on hand the screws to be used. Drop a few of them into the rail groove, and check and adjust the brush height as directed below.

After the brush is placed in a horizontal position as shown below, rotate the brush. When the resultant gap between the brush center end and employed screw heads is approximately 0 mm, no adjustments are needed.

If any adjustments are needed, perform the following procedure.

Loosen the brush mounting screws.

Make adjustments so that the gap between the brush center end and employed screw heads is approximately 0 mm. In this instance, avoid lowering the brush to excess. After completion of adjustments, tighten the brush mounting screws.

As far as the brush is properly leveled, the front-rear V-groove in the screw bin upper end is in alignment with the rail upper surface prevailing when the brush is in an upright position.

After the brush is properly adjusted, rotate it again to verify that it smoothly moves without exhibiting resistance.

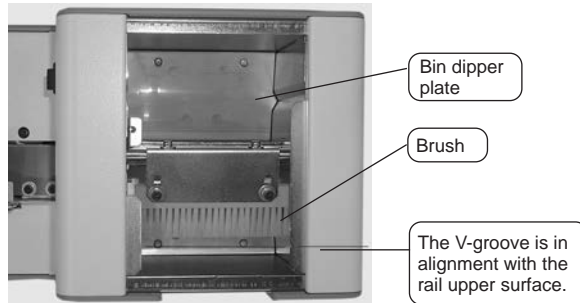

Turn off the power switch before performing any check/adjustment procedure. The switch shown below is in the off position.

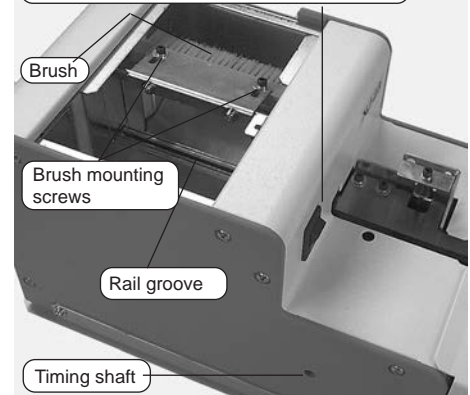

Ensure that the gap between the brush center end and employed screw heads is about 0 mm.

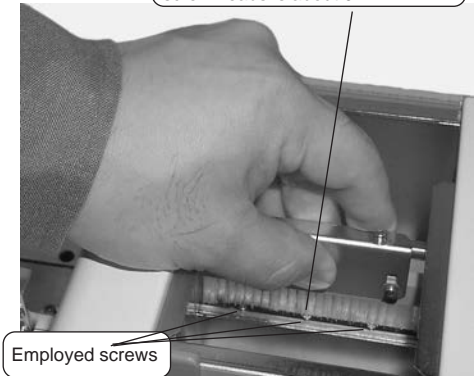

4-3. Checking and Adjusting the Passage Plate

Drop the employed screws into the rail groove. Slide the screws to the passage window section and check or adjust the passage plate height.

Check that the clearance between the passage window upper end and the screw heads is not greater than about 0.5 mm and that the screws can pass the passage window.

If the above requirements are not met, perform the following adjustment procedure.

Loosen the passage plate retaining screw. Move the passage plate up or down to reduce the clearance between the passage window upper end and screw heads to about 0.5 mm or less and permit the screws to pass the passage window.

After completion of adjustments, tighten the passage plate retaining screw.

If the employed screw has a relatively short shank, fine adjustments are needed. For screws having a relatively long shank, however, coarse adjustments will suffice.

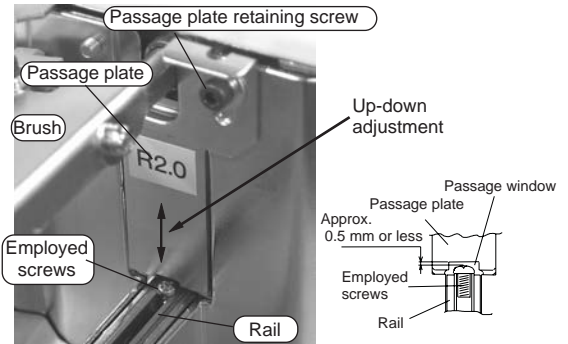

4-4. Checking and Adjusting the Holding Plate (Screw Guide 1)

Drop about 10 employed screws into the rail groove.

Tilt the machine or operate it so that the screws are shifted to the escaper section.

If the shutter is closed or there is no clearance between the holding plate (screw guide 1) and screw heads, the screws cannot move. The screws can move when the shutter is open with an adequate clearance provided between the holding plate (screw guide 1) and screw heads.

When the clearance is 0 to 1 mm, the holding plate (screw guide 1) height needs no adjustment.

NOTE: If the escaper section captures a screw and brings the machine to a stop immediately after you operate it, adjust the timer setting control on the rear of the unit.

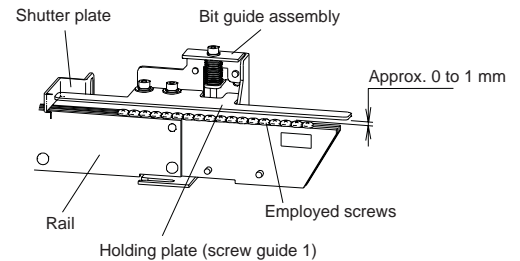
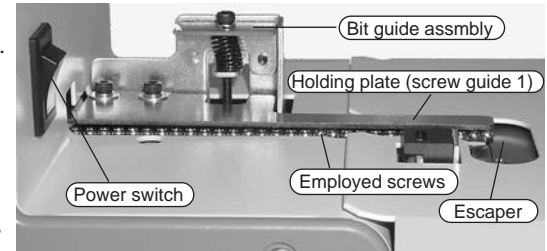

If the holding plate (screw guide 1) height needs to be adjusted, proceed as directed below.

Tilt the machine or operate it so that the screws are shifted to the escaper section. If there is no clearance between the holding plate (screw guide 1) and screw heads, the screws cannot move. The screws can move while the shutter is open with an adequate clearance provided between the holding plate (screw guide 1) and screw heads.

If the screws do not move to the escaper section, loosen the bit guide assembly retaining screw, and rotate the bit guide assembly up-down adjustment screw counterclockwise with the accessory Allen wrench to move the holding plate (screw guide 1) upward. Adjust the holding plate (screw guide 1) height by rotating the bit guide assembly up-down adjustment screw to provide a clearance of 0 to 1 mm between the holding plate (screw guide 1) and the heads of the employed screws.

When performing the above adjustment procedure, ensure that the gap between the holding plate (screw guide 1) and rail is uniform. You should particularly make sure that the gap provided for the rear side of the unit is not smaller than the front one.

After completion of adjustments, be sure to tighten the bit guide assembly retaining screw.

If the employed screw has a relatively short shank, fine adjustments are needed.

For screws having a relatively long shank, however, coarse adjustments will suffice.

4-5. Checking and Adjusting the Rail Assembly and Escaper Components

The machine is factory adjusted for pan-head screws prior to shipment. Under normal conditions, you do not have to readjust the rail assembly or escaper components.

However, if the employed screws have an extremely thin head or a smaller diameter, it may be necessary to perform a check/adjustment procedure. To check or adjust the rail assembly and escaper components, you have to remove the four mounting screws to take off the escaper cover.

NOTE: After the rail has been removed for cleaning or the rail or escaper has been replaced for a change in the employed screw size, be sure to adjust the escaper components and rail assembly. The replacement procedures are detailed in Section 6-3, Replacement Procedures.

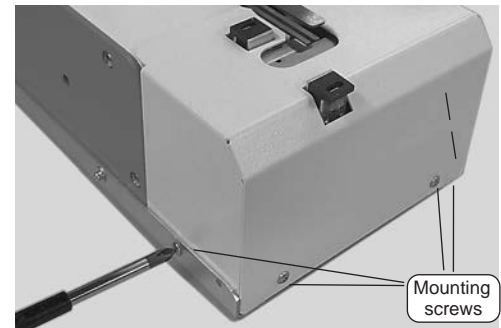
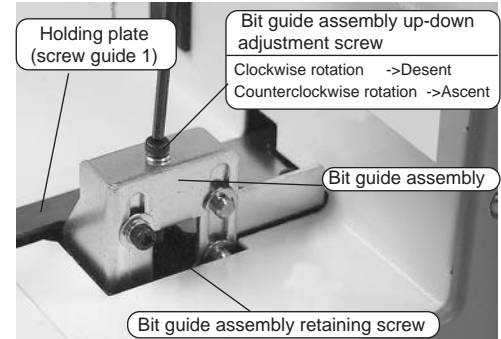

When the employed screws move along the rail, the escaper receives one of them and moves it to the screw removal section (sensor optical axis). In this state, the employed screw is retained in the removable position. The employed screw can be removed only when the escaper is positioned as shown at right. When you remove the screw from outside, the escaper operates to receive the next screw and retains it in the removable position. When there is no screw in the removable position, the escaper continues its reciprocating motion. The escaper operation is controlled by the sensor.

If the employed screw has an extremely thin head, the sensor may fail to detect it. If the sensor does not achieve detection, the escaper does not stop running even if it retains the employed screw. In such an instance, you have to complete the following adjustment procedure.

Turn off the power switch and let an employed screw be retained by the escaper.

Loosen the sensor bracket assembly mounting screw and shift the sensor bracket assembly about 0.1 to 0.5 mm downward. Turn the mounting screw finger-tight.

Turn on the power switch and verify that the sensor detects the employed screw to inhibit the escaper from operating. Take out the retained employed screw and verify that the escaper operates.

After completion of checkout, fully tighten the mounting screw.

NOTE: If you lower the sensor bracket assembly to excess, the sensor actuates to inhibit the escaper from operating even when the escaper does not retain an employed screw.

(Reference)

You can observe the sensor output voltage level when you remove the main body rear cover and measure the voltage with the pin 7. Note that the metal portion of the unit provides a signal ground.

The measured voltage should normally be as follows:

When there is a screw in the removal section: 3.5V or higher

When there is no screw in the removal section: 0.25 V - 1.5V or lower

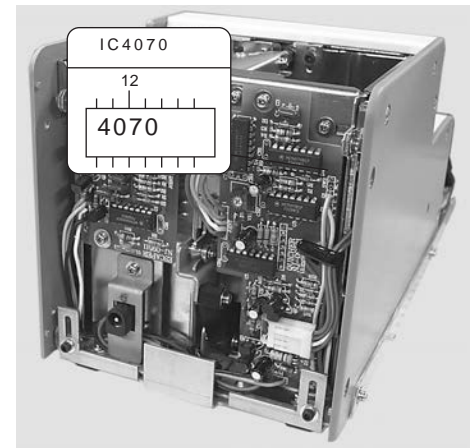
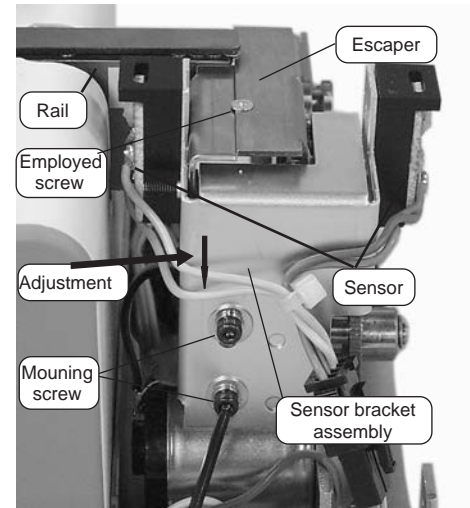

If the escaper operates in such a manner that the employed screws are not readily retained by the escaper, perform the following check/adjustment procedure.

- Check that the clearance between the rail and escaper is properly adjusted. The clearance should ideally be as small as possible. Fine adjustments are needed particularly when the employed screws have a small diameter.

Adjustment procedure:

Adjust the rail assembly mounting position (front-rear adjustment)

NOTE1: Make adjustments so that the rail end does not come into contact with the escaper when the rail vibrates.

NOTE2: After adjustments, be sure to tighten the rail front-rear position lock screw.

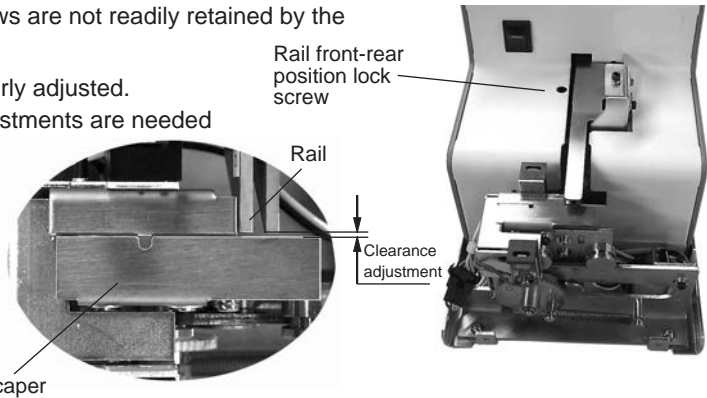

- Check that the rail groove is in alignment with the escaper groove. When the escaper moves to receive an employed screw from the rail, it is ideal that the rail groove is in alignment with the escaper groove. Fine adjustments are needed particularly when the employed screw diameter is small.

Adjustment procedure:

Adjust the rail bracket stopper mounting position (left-right adjustment).

NOTE: After adjustments, be sure to tighten the mounting screw.

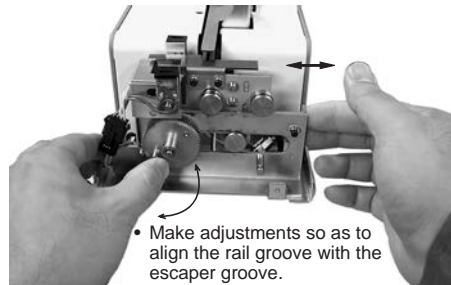
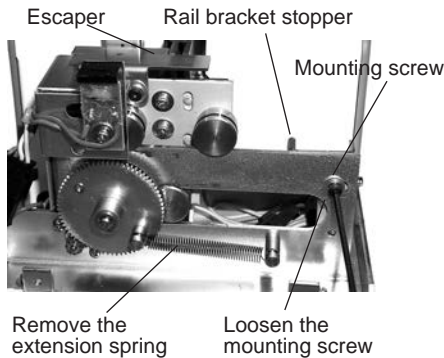

- Make adjustments so as to align the rail groove with the escaper groove.
- After adjustments, tighten the mounting screw and set the extension spring in position.

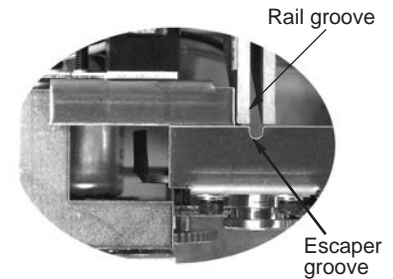

5. Operating Procedures and Operational Checks

5-1. Loading the Screws

Remove the screw bin lid.

While the bin dipper plates are at the lowest position, you can pour in the screws until they are piled up to about 3 mm from the rail upper surface. Ensure that the screws are equally distributed into the right- and left-hand bins.

Exercise care not to load the screws to excess.

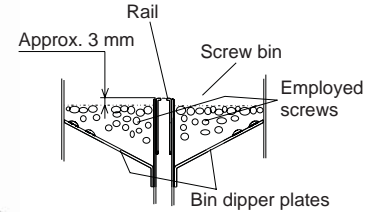

**Do not to load
the screws to excess.**

5-2. Operating the Machine

Connect the accessory AC adapter plug to the DC jack on the rear of the machine. Connect the AC adapter to a power outlet.

Turn on the machine power switch. The lamp incorporated in the power switch then comes on.

Turning on the power switch causes the drive motor to rotate normally, the bin dipper plates to move up and down, and the rail to vibrate. The escaper reciprocates at the same time. After a while, the loaded screws are sequentially transported along the rail groove and delivered to the escaper. The escaper picks a screw and retains it in the removable position. If you do not remove the screw from the removable position for a predetermined period of time, the machine comes to a stop. The moment the screw is removed, the machine resumes operation.

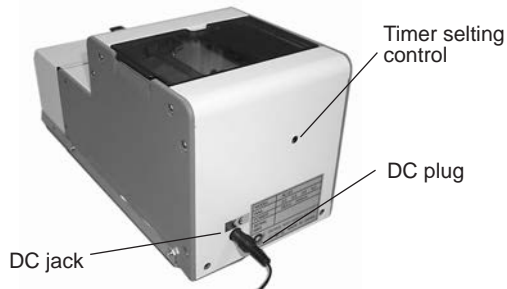

Power switch
(lamp-incorporated)



Operational features

The machine is equipped with an overload protection circuit.

If a movable section is overloaded during a machine operation due, for instance, to a trapped screw or other article or excessive screw introduction into the screw bins, the overload protection circuit actuates.

Function descriptions and remedies

Under normal conditions, the drive motor in the machine rotates in normal direction to feed the loaded screws continuously to the escaper section, thereby allowing you to obtain the screws successively. However, if any movable section is overloaded, the drive motor rotates in reverse direction for a predetermined period of time and then resumes its normal rotation. When the cause of the movable section overload is eliminated upon motor reversal, the motor reverts to normal rotation, permitting you to obtain the screws continuously.

If the cause of the movable section overload is not eliminated upon motor reversal, the overload protection circuit performs the reverse rotation and normal rotation repetition cycle for a predetermined period of time and then shuts off the power supply to the drive motor. In this instance, however, the escaper continues operating.

When the power to the drive motor shuts off as above, turn off the power switch and then eliminate the cause of the overload. If, for instance, the screw bins are overloaded with screws, reduce the number of screws in the bins. If a screw or other article is trapped in a movable section, remove it.

After the cause of the overload is eliminated, turn the power switch back on (power-on reset) and use the machine.

The machine is equipped with a timer.

You can adjust the timer setting as appropriate for the employed screw type.

Function descriptions

The screw feed speed varies with the employed screw type.

The machine continues running while there is no screw in the screw removal area of the escaper section. It stops its operation when a predetermined period of time elapses after a screw is retained in the removal section. This duration of time can be adjusted with the timer setting control on the rear of the machine.

It is recommended that you decrease the timer setting when the feed speed for the employed screw type is high and increase the setting when the feed speed is low.

When adjusting the timer setting, exercise care not to rotate the control beyond the permissible range.

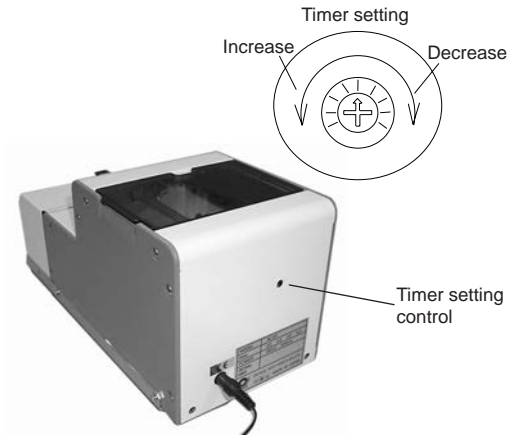

The machine is equipped with an external output signal cable.

The incorporated signal cable enables you to obtain a signal that indicates whether a screw is present in the escaper section screw removal area.

This signal wire shall be use with automatic assembly machines or external screw counters.

[Function] Screw present :Signal high(ON)

Incoming current: shall be limited to less than 100mA

****CAUTION:** Additional resistor is required on externally circuit for regulating current**

[Capacity]: Max DC current: 100mA

External supply voltage: 5-24VDC (Max. 27V)

[Caution] :Please keep the length of output signal wire less than 3m;

*The purple wire functions as signal output high(Collector end),
with the gray wire as common

Purple line — — — > Signal line(OFF when no screw is present)
(On when a screw is present)

Gray line — — — > Common line

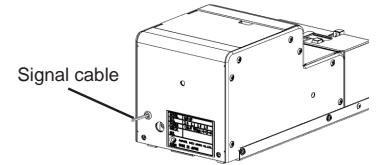

The machine is equipped with a tilt mechanism.

When the screw feed speed is low, you can install the machine in a tilted position.

Descriptions

Loosen the tilt lock screws.

Pull out the base bracket from the rear of the machine and fix it in an appropriate position.

After the machine is tilted in this manner, make sure that it is steady.

Do not tilt the machine beyond the capacity of the tilt mechanism.

Example

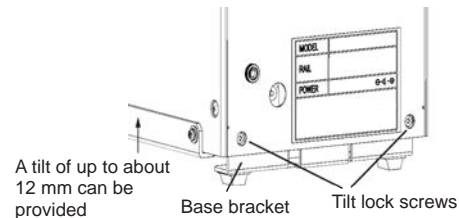
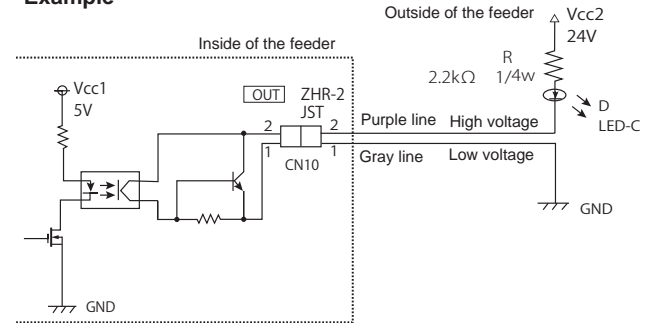

6. Maintenance



CAUTION

Before performing any maintenance, turn off the power switch and remove all the loaded screws from the machine.

6-1. Cleaning the Rail and Rail Guide Wall Surface

When the rail groove is soiled, the screw feed speed may lower. If such a situation is encountered, wipe the rail groove clean with a thin, clean cloth moistened with alcohol.

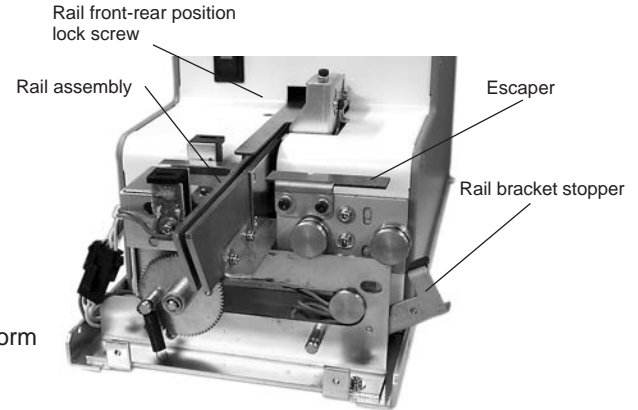
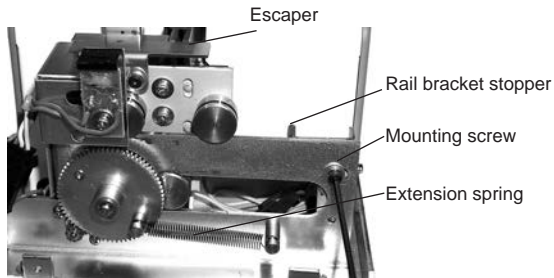

If the rail groove is heavily soiled, remove the rail assembly and then perform cleaning.

Remove the escaper cover.

Remove the extension spring.

Remove the rail bracket stopper mounting screw.

Rotate the rail bracket stopper to move the escaper to the right.

Loosen the rail front-rear position lock screw and then pull the rail assembly forward and out.

With a thin, clean cloth moistened with alcohol, wipe clean the rail groove and upper and lateral surfaces of the removed rail assembly.

With a thin, clean cloth moistened with alcohol, wipe clean the rail guide wall surface, which is revealed upon rail assembly removal.

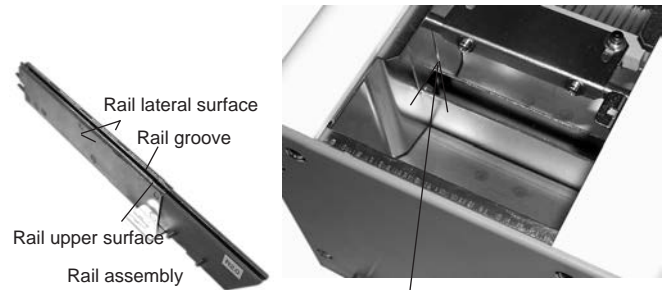

6-2. Installing the Rail Assembly and Escaper Components

After cleaning, achieve rail section reassembly by reversing the rail assembly removal procedure. Be sure to lodge the escaper drive gear pin in the escaper rail groove.

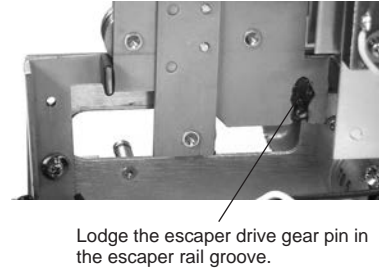
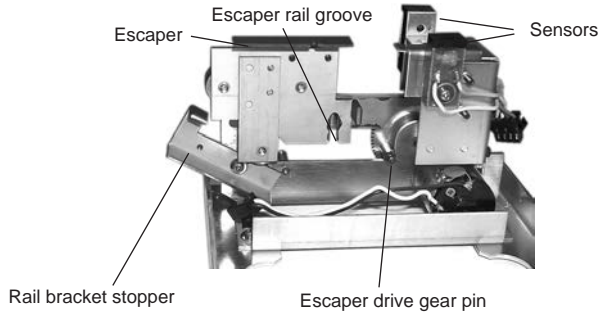

Complete rail assembly installation and escaper position adjustments as indicated on page 9.

- Adjusting the clearance between the rail and escaper
- Aligning the rail groove and escaper groove

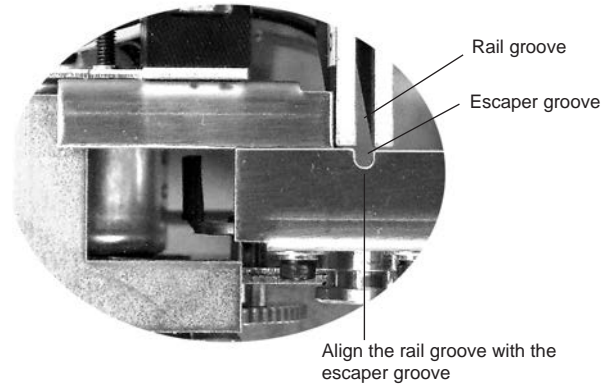
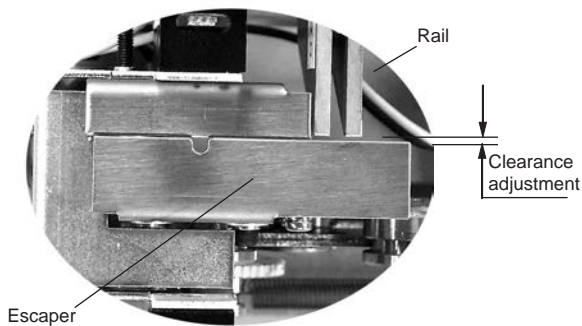

6-3. Replacement Procedures

- Replacing the rail assembly

The rail assembly of the machine can easily be replaced.

If the loaded screws do not smoothly feed after cleaning or if you intend to use a different screw diameter, replace the rail assembly.

For the replacement procedure, see the earlier section on cleaning.

- Replacing the passage plate and escaper

The machine allows you to change the screw diameter setup by replacing some components.

(this change can be made even if you do not change the machine type)

To change the screw diameter, you have to replace the passage plate and escaper in addition to the rail assembly.

To replace the passage plate, remove its retaining screw.

Replace the passage plate in such a manner that the brush is positioned as shown at right.

Exercise care not to lose the retaining screw.

To replace the escaper, you have to remove its mounting screws.

Remove the extension spring, shift the escaper to the right as shown at right, remove the mounting screws, and replace the escaper.

After the rail assembly and escaper have been replaced, it is necessary to adjust the escape section.

The adjustment procedure is indicated on pages 17 and beyond.

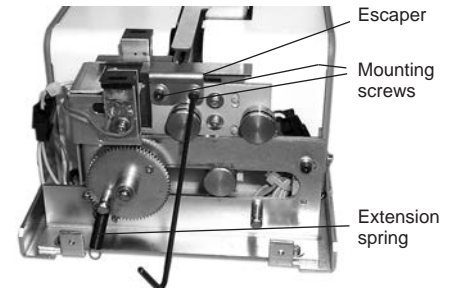
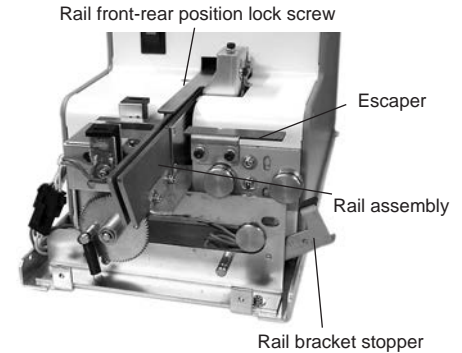

- Replacing the brush

If the ends of the brush bristles are worn so that improperly oriented screws cannot be swept away, replace the brush with a new one.

To replace the brush, position it as shown.

You can adjust its position by rotating the timing shaft.

Remove the brush assembly mounting screws and then the brush assembly. You can disassemble the brush assembly.

After the brush is replaced, install the brush assembly by reversing the preceding steps.

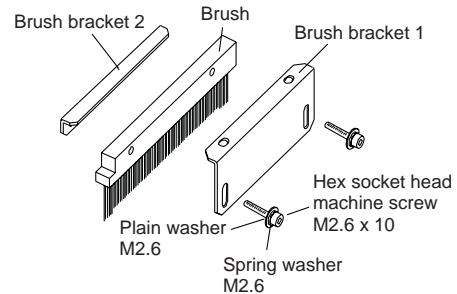
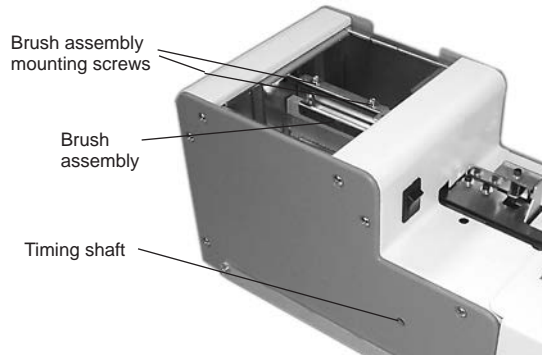

Brush assembly exploded view

All the above replacement parts are available as options. When they need replacement, contact your local dealer and specify the machine model number, part names, and part model numbers.

Adjustments to be made after rail assembly/escaper replacement

- ① Adjust the clearance between the rail assembly and escaper. ---> Adjust the rail assembly mounting position (front-rear adjustment)

The clearance should be minimized. Fine adjustments are needed particularly when the employed screws have a small diameter. For the adjustment procedure, see page 9.

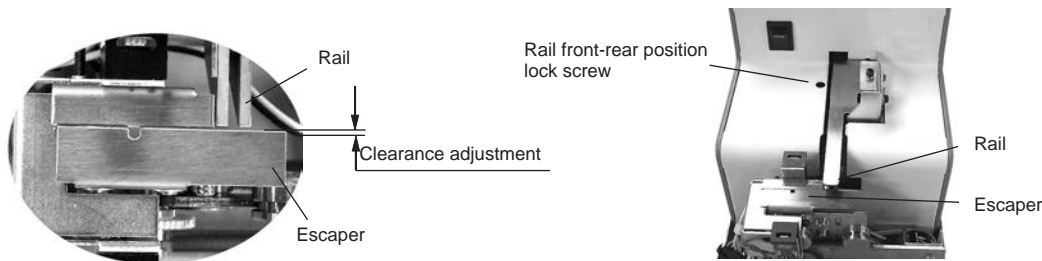

- ② Adjust the escaper height relative to the rail. ---> Adjust the escaper mounting position (height adjustment).

Ensure that the height deviation of the escaper upper surface from the rail upper surface is 0 to -0.3 mm or so. Also, be sure that the escaper is placed in a horizontal position. Fine adjustments need to be made to reduce the height difference to about 0 mm particularly when a small screw diameter is employed.

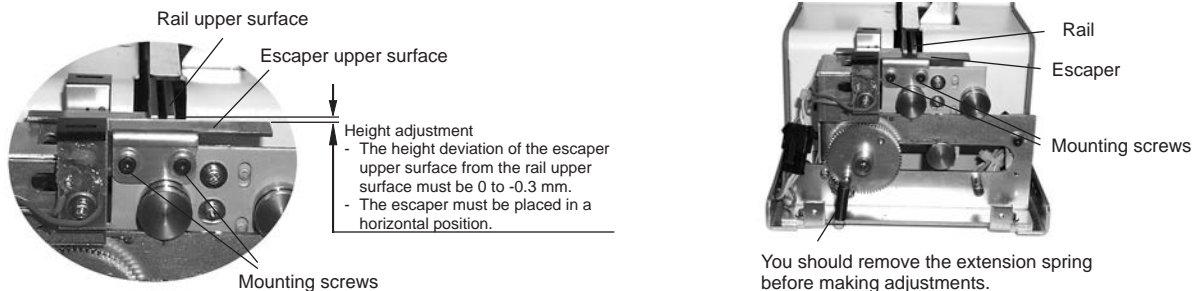

You should remove the extension spring before making adjustments.

- ③ Adjust the clearance between the rail lateral surface and escaper screw receiver. ---> Adjust the escaper screw receiver mounting position (left-right adjustment).

Position the escaper screw receiver so that a clearance of about 0.1 to 0.3 mm is provided between the rail lateral surface and escaper screw receiver. Fine adjustments need to be made to reduce the clearance particularly when a small screw diameter is employed. Accomplish vertical positioning by pressing the escaper screw receiver end face against the half-blanked portion of the sensor bracket.

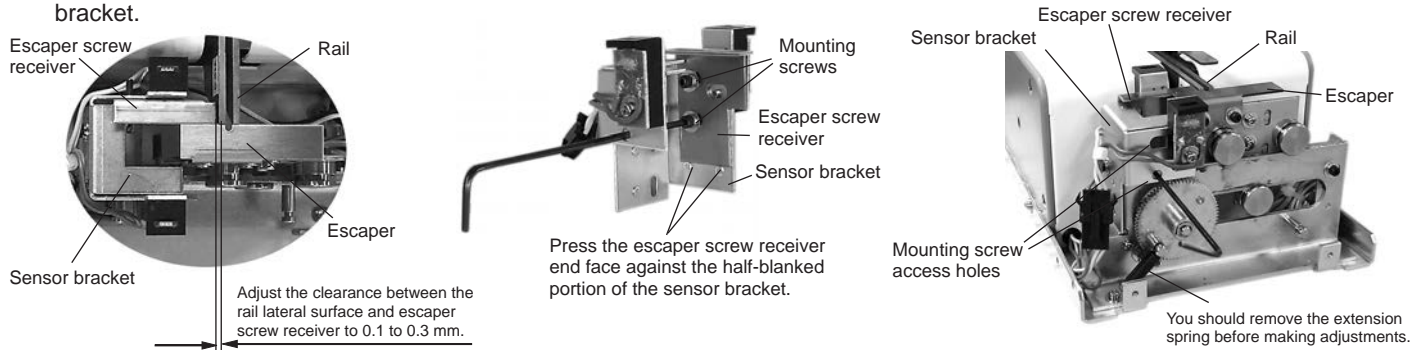

- ④ Adjust the height relationship between the escaper screw receiver upper surface and escaper upper surface. ---> Adjust the sensor bracket assembly mounting position (height adjustment).

Position the sensor bracket assembly so that the height deviation of the escaper screw receiver upper surface from the escaper upper surface is 0 to -0.5 mm or so. The escaper screw receiver adjusted in step ③ must not be repositioned here.

Make fine adjustments as directed on pages 7 and 8 when the employed screw has an extremely thin head or small diameter.

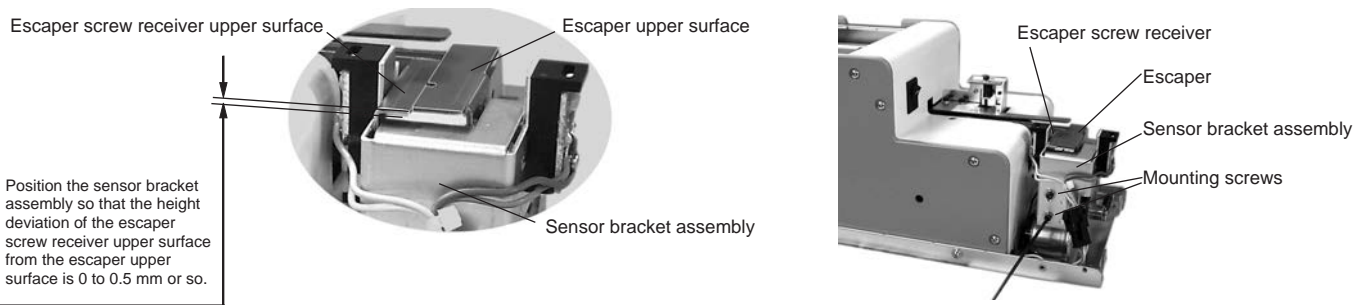

- ⑤ Adjust the positional relationship between the rail groove and escaper groove. ---> Adjust the rail bracket stopper mounting position (left-right adjustment)

Position the rail bracket stopper so that the escaper groove is aligned with the rail groove when the escaper moves to receive a screw from the rail. Fine adjustments need to be made particularly when the employed screw diameter is small. For the adjustment procedure, see page 9.

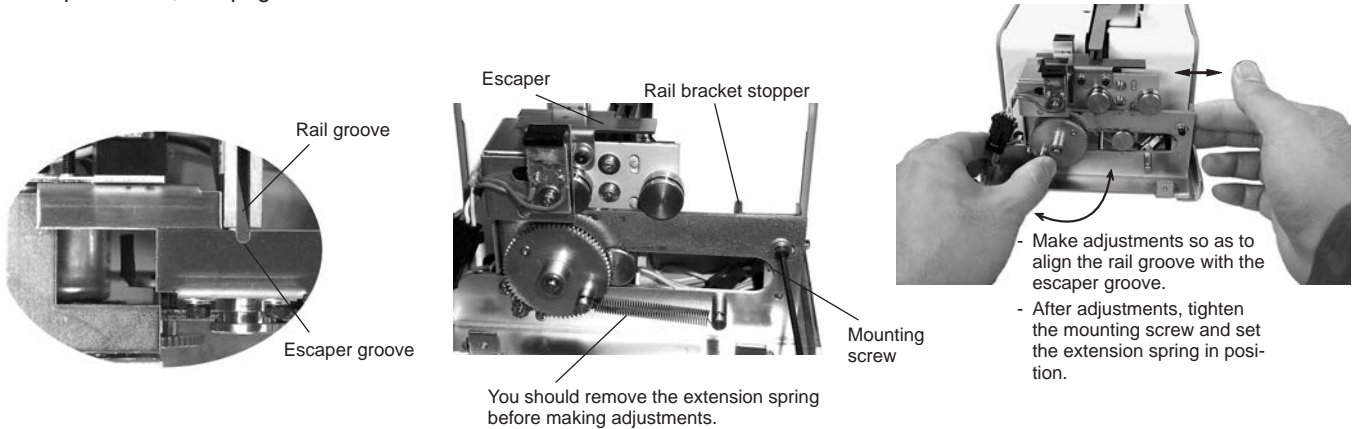

After rail assembly and escaper replacement, be sure to perform steps ① through ⑤ above for readjustment purposes.

After completion of adjustments, operate the machine to perform the following operational checks.

- Check that screws are smoothly delivered from the rail to the escaper.
- Check that the sensor detects a screw in the removal section and brings the escaper to a stop. Also, check that the escaper resumes operation when the screw is removed.

If any improper operation is encountered, perform adjustment steps ① through ⑤ again.

7. Troubleshooting Guide



CAUTION Before taking any remedial action, turn OFF the power switch.

Problem	Cause	Remedy
<p>7-1 The machine does not start when power switched on.</p>	<ul style="list-style-type: none"> • No power is supplied. • The screw in the removal section has not been removed for a predetermined period of time. 	<ul style="list-style-type: none"> • Ensure that the AC adapter is properly connected to a power source. • Remove the screw from the removal section. Adjust the timer setting control.
<p>7-2 Loaded screws do not feed.</p>	<ul style="list-style-type: none"> • The diameter of the loaded screw does not match the employed rail. • The number of screws in the screw bins is too low. • The brush cannot sweep an abnormally oriented screw away from the passage window section. • A screw shank has been trapped in the passage window. • An abnormally oriented screw is stuck in the rail section. • The rail does not vibrate (a screw or foreign object is trapped in a gap). • The timer setting control is improperly adjusted. 	<ul style="list-style-type: none"> • Switch to the machine that is suitable for the screw size. Use the rail that fits the screw. • Load additional screws into the screw bins. • Adjust the brush. Adjust the passage plate. The problem may also be cleared by adding some screws to the screw bins. • Remove any abnormally oriented screw and then adjust the passage plate. • Remove the abnormally oriented screw as indicated below. Loosen the bit guide assembly retaining screw, shift the holding plate(screw guide 1) upward, and remove the abnormally oriented screw. After screw removal, readjust the holding plate (screw guide 1). • Remove the trapped screw or foreign matter. • Adjust the timer setting control.
<p>7-3 A loaded screw has become lodged in the rail groove.</p>	<ul style="list-style-type: none"> • The diameter of the loaded screw does not match the employed rail. • The total length of the loaded screw is less than the rail groove width. 	<ul style="list-style-type: none"> • Switch to the machine that is suitable for the screw size. Use the rail that fits the screw. • This problem cannot be remedied.

Problem	Cause	Remedy
<p>7-4 The screws on the rail do not feed smoothly.</p>	<ul style="list-style-type: none"> • The clearance between the holding plate (screw guide 1) and screw heads is insufficient. • Dirt, oil, or grease is attached to the rail. • The rail fails to vibrate due to a screw or foreign object trapped in a gap. 	<ul style="list-style-type: none"> • Shift the holding plate (screw guide 1) upward. Use the machine in a tilted position. Adjust the timer setting control. • Clean the rail and rail guide. • Remove the trapped screw or foreign object and then clean the rail and rail guide.
<p>7-5 Abnormally oriented screws are occasionally allowed to travel through the passage window. A screw shank readily lodges in the passage window.</p>	<ul style="list-style-type: none"> • The passage plate is improperly adjusted. • The employed passage plate does not match the loaded screw. • The forward-descending tilt of the machine is above the permissible limit 	<ul style="list-style-type: none"> • Readjust the passage plate. • Use the passage plate that matches the loaded screw. • Ensure that the forward-descending tilt is within the permissible limit.
<p>7-6 Screws are not transported to the removal section.</p>	<ul style="list-style-type: none"> • Screws are stopped in the middle of the rail section. • Screws are not smoothly transferred from the rail to the escaper. 	<ul style="list-style-type: none"> • Readjust the holding plate (screw guide 1). • Readjust the positional relationship between the rail end and escaper.
<p>7-7 The machine comes to a sudden stop.</p>	<ul style="list-style-type: none"> • The overload protection circuit is activated due to overloading. • The screw in the removal section has not been removed for a predetermined period of time. 	<ul style="list-style-type: none"> • Turn the power switch off and then back on. If the operation comes to a stop again, the probable causes are: There are too many screws in the screw bin. ---> Adjust the number of screws in the screw bins. A screw or foreign object is trapped in a movable section. ---> Remove any trapped screw or foreign object. - Remove the screw.

Problem	Cause	Remedy
7-8 The bin dipper plates fail to stop moving when there is a screw in the removal section.	<ul style="list-style-type: none"> • The timer setting control is improperly adjusted. 	<ul style="list-style-type: none"> • Readjust the timer setting control.
7-9 The escaper plates fail to stop running when there is a screw in the removal section.	<ul style="list-style-type: none"> • The screw is not detected by the sensor in the escaper section. 	<ul style="list-style-type: none"> • Readjust the sensor bracket assembly.
7-10 Screws have been dislocated and dropped inside the machine housing.	<ul style="list-style-type: none"> • The holding plate (screw guide 1) is improperly adjusted. • The front-rear position of the rail is improperly adjusted. 	<ul style="list-style-type: none"> • Readjust the holding plate (screw guide 1) • Readjust the front-rear position of the rail.

8. Specifications

Exclusive adapter (Switching type)	Input: AC100-240V 50/60Hz Output: DC 15V 1A
Dimensions	134(W) x 274(D) x 139(H) mm
Weight	Approx. 4.4kg
Screw capacity	150cc
Included Accessories	CD-ROM x 1 AC Adapter x 1 Hexagonal Wrench x 1 Screwdriver x 1 Ground wire x 1

NOTES

-Measure the shank diameter of the screw to be used and then check whether it matches the rail groove reference dimension.

-Within The range of screw size and length below,there may be instances of unique screw shape or structure not compatible with this machine unit. Please consult with distributor or manufacture for further infomation.

-You can change the model without changing the type.

-To change the screw size (nominal diameter), replace all the associated replacement parts.

-The replacement rails, escapers, passage plates, and brushes are available as options.

-The product design, performance characteristics, and other specifications are subject to change and improvement without prior notice.

Screw feeder model	Applicable Screw Reference Table						Screw head shape					
	Screw size	Screw shaft diameter (mm)	Screw head diameter (mm)	Washer diameter (mm)	Screw head height (mm)	Screw length (under head portion)(mm)	Pan head	Pan head			Bind	Counter sunk
								Sems	Double sems	Washer head		
HS-35RB	M3.5	3.3 - 3.7	4.8 - 8.0	4.8 - 12	0.5 - 8.0	5.6 - 18	○	○	○	○	○	○
HS-40RB	M4.0	3.8 - 4.1	5.4 - 8.0	5.4 - 12	0.5 - 8.0	6.4 - 18	○	○	○	○	○	○
HS-50RB	M5.0	4.8 - 5.1	6.2 - 10.0	6.2 - 12	0.5 - 8.0	8.0 - 18	○	○	○	○	○	○

* Compatible with washer thickness 0.4 to 1.0mm.

Specifications

Model	Nominal screw diameter	Rail model No.	Passing plate model No.	Escaper guide of the robot model No.
HS-35RB	M3.5	HS-R35RB	HS2-01008-35	HS2RB-06506-35
HS-40RB	M4.0	HS-R40RB	HS2-01008-40	HS2RB-06506-40
HS-50RB	M5.0	HS-R50RB	HS2-01008-50	HS2RB-06506-50

Replacement rails, escapers, and passage plates are available as options. In the Exchange Kit ordered separately, rails, escapers and passage plates are included.

Replacemnt parts

Rail

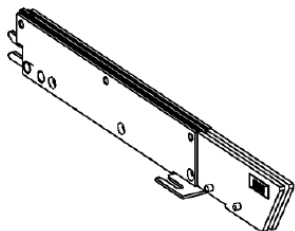

Escaper

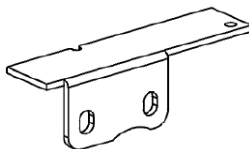

Passage plate



Brush assembly

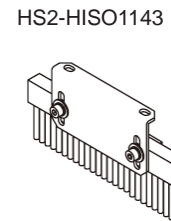

HS2-HISO1143

Motor drive assembly

HS2-04501

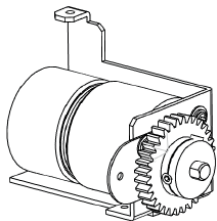

Motor

HS2RB-09582-08

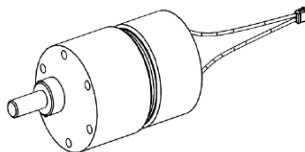

Escaper motor

HS2RB-06640,

HS2RB-09582-06 (Serial No. 2SR171XXXX - 2SR179XXXX,
previous serial No. including 2SR16XXXXX).

9. External dimension

The dimensions in the manuals are for reference only do not use it for your jig.
The specifications are subject to change without notice.

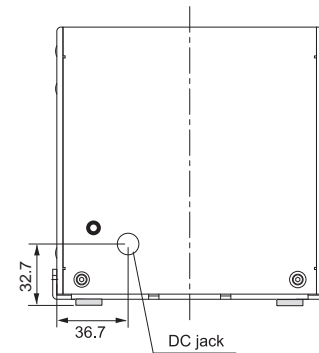
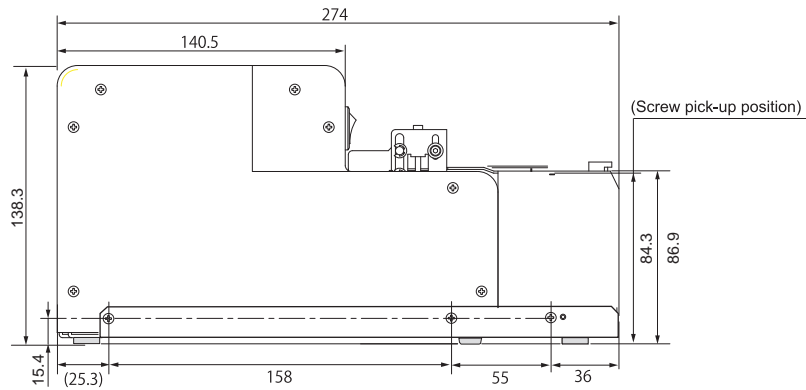
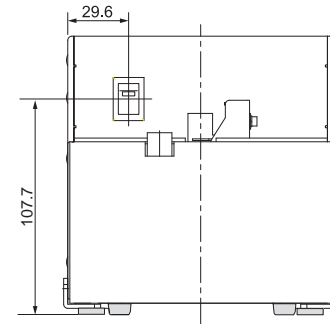
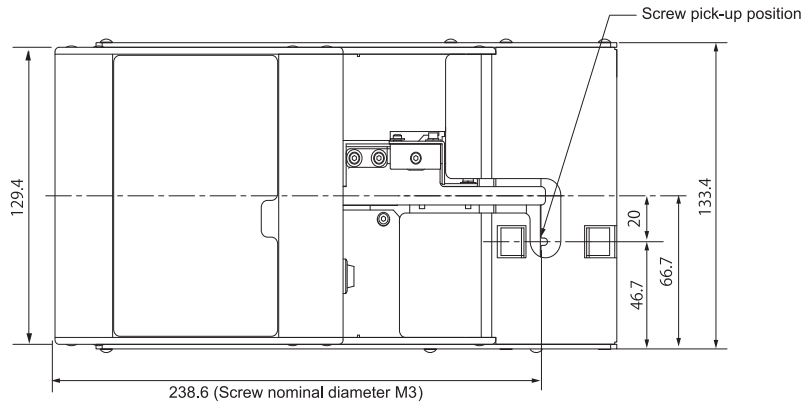

10. The following table is for China RoHS2.

If you are asked by China Customs, please show this table to them.

有害物质名称及含量标识格式						
产品中有害物质的名称及含量						
部件名称	有害物質					
	铅(pb)	汞(Hg)	镉(Cd)	六价铬 (CR(VI))	多溴联苯 (PBB)	多溴二苯醚 (PBDE)
驱动齿轮, 轴心部件	×	○	○	○	○	○
铆钉	×	○	○	○	○	○
六角铜柱	×	○	○	○	○	○
电路板元件	×	○	○	○	○	○
连接器	×	○	○	○	○	○
-						
-						
-						

本表格依据 SJ/T 11364 的规定编制。
 ○：表示该有害物质在该部件所有均质材料中的含量均在 GB/T 26572 规定的限量要求以下。
 ×：表示该有害物质至少在该部件的某一均质材料中的含量超出 GB/T 26572 规定的限量要求。

In addition, the China RoHS marks also is required at the product and product box.

At the product, you can find it at the bottom and it is marked on the product box.

If you cannot find the mark, please ask your distributor.

In case of emergency, please cut the mark below and stick at the bottom of product and on the product box.

China RoHS mark

