

Neji Taro III

HS III series

HS III-10

HS III-12

HS III-14

HS III-17

HS III-20

HS III-23

HS III-26

HS III-30

Instruction Manual

Read this manual before using this device.

Current as of October 2021

HIOS Inc.

1-35-1 Oshiage, Sumida-ku Tokyo, Japan 131-0045

TEL: +81-3-6661-8821 FAX: +81-3-6661-8828

CONTENTS

1) BEFORE USE.....	3
2) FOR SAFE USE.....	3
3) NAME OF MACHINE PARTS.....	5
4) ADJUSTMENTS AND CHECKS BEFORE USE.....	6
5) OPERATING INSTRUCTIONS.....	14
6) REPLACEMENT OF CONSUMABLE PARTS.....	15
7) EXTERNAL OUTPUT SIGNALS.....	20
8) TROUBLESHOOTING.....	21
9) SPECIFICATIONS.....	26
10) EXTERNAL DIMENSIONS.....	28
11) THE FOLLOWING TABLE IS FOR CHINA RoHS2.....	29



Cautions

Be sure to follow the cautions, or it could lead to serious damage, such as injuries, electric shock, and damage properties.

1) BEFORE USE

Thank you very much for selecting our Automatic Screw Feeder "HS III series". Please check the following accessories before operating the machine.

- CD-ROM, 1
- AC adapter, 1 piece
- Hexagonal wrench, 1 piece
- Screwdriver, 1 piece
- Ground wire, 1 piece

* For feeder machines purchased outside of Japan, no adaptor will be supplied with the feeder.
Please purchase a separate adaptor with equivalent output specification as required.

2) FOR SAFE USE

Read the following Cautions thoroughly for the safe use of this machine. Keep them in mind during the operation of the machine in order to prevent injuries and damage to property.

Installation

⚠ Caution: Installation Install the machine on a level, stable location that can endure it's weight and running conditions. If the machine falls down or turns over due to improper installation, injuries or property damage may occur.

Operating Environment

⚠ Caution: Do not operate this machine where flammable or corrosive gas is present. It is extremely dangerous to use this machine under such circumstances. Do not operate this machine in environment of high humidity.

Attach the ground wire by loosening the screw near the mark  of the equipment.



the bottom of the main body

AC adapter

Use only the AC adapter supplied with this machine otherwise it may result in a fire or electric shock.

Rail

 **Caution:** Do not damage nor oil the rail.

Screw compatibility

 **Caution:** Do not use screws with grease, dirty screws or any screw other than those prescribed.

Access of screws

 **Caution:** Do not exert excessive or impactive force when accessing the screws.

When machine is not in use

 **Caution:** Be sure to unplug the AC adapter from the wall outlet during closing hours and if the machine will be left unattended for any extended period of time.

Abnormalities during operation

 **Caution:** Stop operation and unplug immediately whenever you sense abnormalities or unusual machine behaviors during the operation of this machine, such as a pungent odor. Turn off the power switch and disconnect the AC adapter from the receptacle. Continued operation may cause fire, electric shock, malfunction or personal injury. Immediately contact the dealer from which you purchased the product.

Servicing

 **Caution:** Do not attempt to repair, disassemble or modify this machine except where specified by this manual.
Consult your dealer for service and repair of this machine.

3) NAMES OF MACHINE PARTS

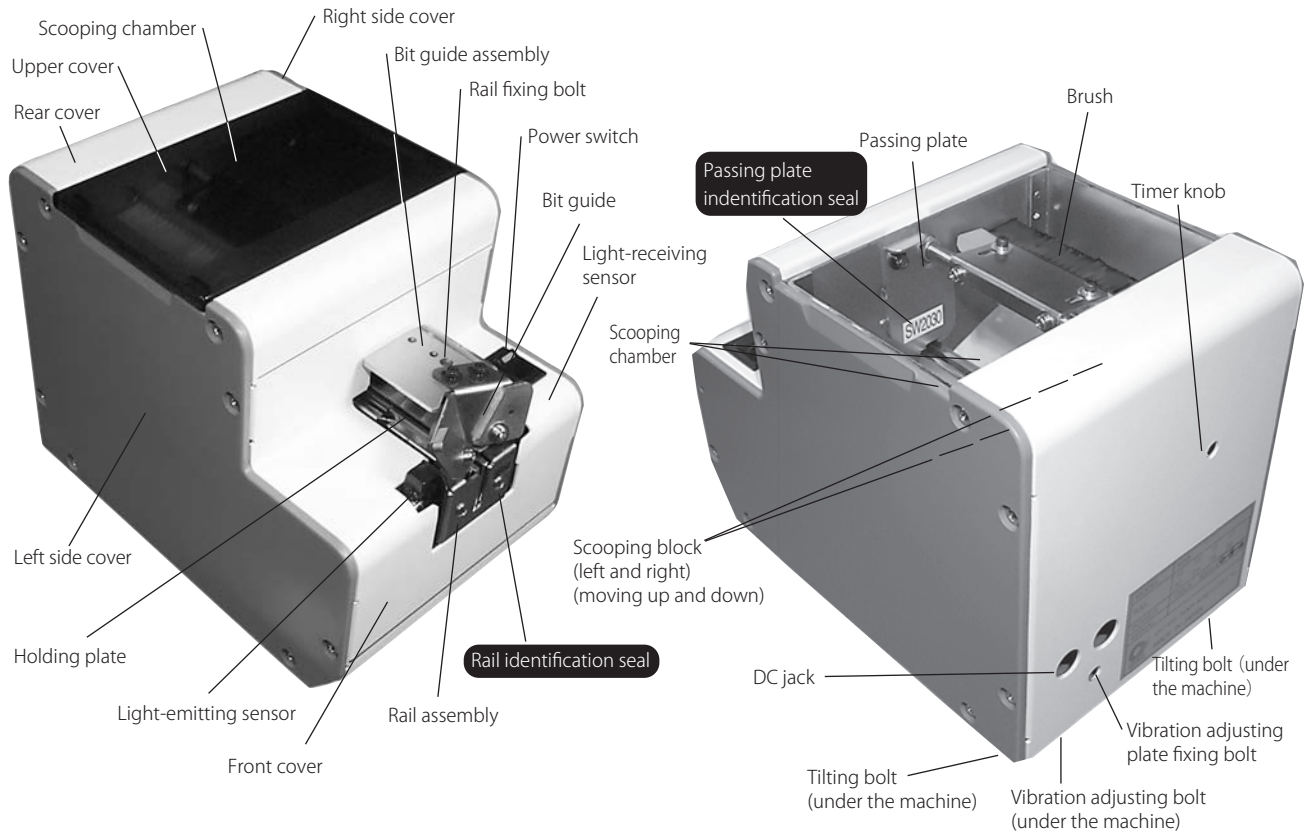

4) ADJUSTMENTS AND CHECKS BEFORE USE

Before using the machine, please check if the rail and components installed on the machine is suitable for the screw applied. The rail is φ 1.0 to φ 3.0 depending on the nominal diameter. It is determined by the identification seal on a rail front cover. There are two kinds of passage plates, namely one for φ 1.0 to φ 1.7 and one for φ 2.0 to φ 3.0. It is determined by an identification seal affixed on a passage plate.

◆ When there is no rail installed on the machine, please install the rail before use.

First, unfasten the rail fixing bolt through the upper bit guide holder.

Insert the rail into the furthest point.

Fasten the fixing bot.

◆ Quantity of screws thrown in

If too many screws are thrown in, orientation and transfer of the screws will be seriously affected. See the diagram on the right for the maximum number of the throw screws in the [scooping chamber].

- Set the [scooping block] in the lowest possible position.
- Throw in screws up to a position of 2 mm to 3 mm below the rail groove face.
- In this condition, ensure that the front inclined-face of the ramp is not hidden by the screws.

Ensure that the rail groove face is not hidden by the screws.
(Screws should be positioned 2 to 3 mm below the rail groove.)

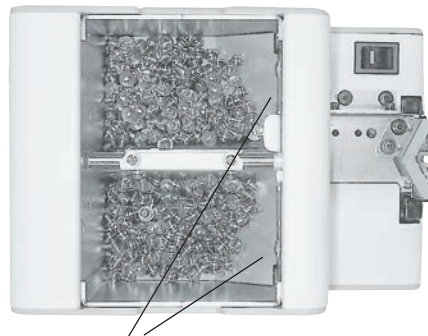

These parts of the inclined face of the ramp should be use underline.

◆ Adjustment of the brush

Check the height of the brush.

- As in the picture on the right, set the brush to an approximately level position.
- Ensure that the edge of the brush is grazing the screw's head.
- If the height of the brush is either too low or too high, orientation and transfer of the screws will be seriously affected.
- If adjustment is necessary, adjust it by loosening the brush height adjusting screw.

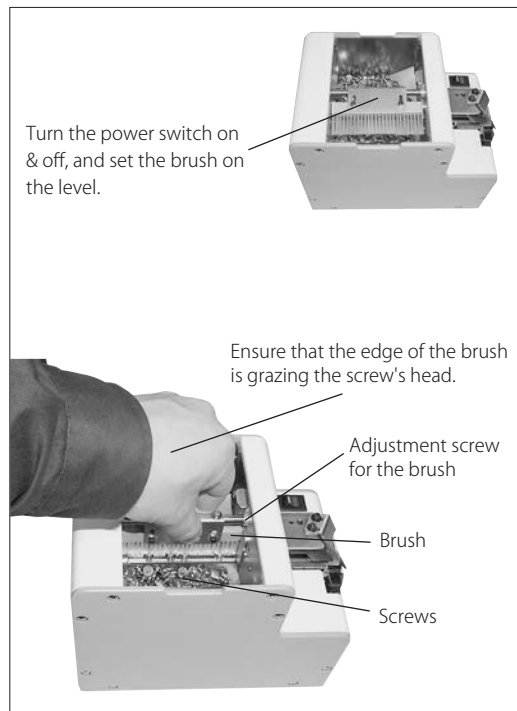

◆ Adjustment of the holding plate

Check the position of the holding plate.

- ensure that the gap between the head of the used screw in the rail groove and the holding plate is approximately 0.2 mm to 1 mm.
- If there is no gap, the screw gets caught. If the gap is too large, the screw overlaps or juts out.
- If adjustment is necessary, adjust it up or down by loosening the bit guide bracket attaching screw.

Easily adjust it by using the 0.35 mm gauge plate.

Loosen the bit guide bracket attaching screw. Insert the gauge between screws on the rail and the holding plate. Tighten the bit guide bracket attaching screw when the holding plate is touching the front and the back of the gauge equally.

⚠ Caution: Matching the center of the holding plate outlet and the rail center may be necessary.

- Ensure that the center of the holding plate outlet matches the rail center.
- If not, adjust it by loosening the attaching screw.

Holding plate

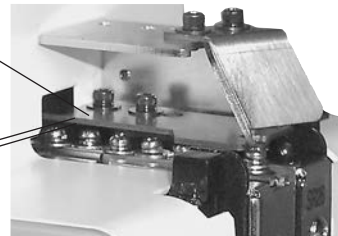

The gap between the holding plate and the head of screws should be 0.2mm to 1mm. The holding plate and the rail should be parallel, too.

The bit guide bracket attaching screws

Adjustment of the height

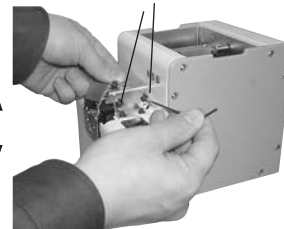

Attaching screws

Match the center of the holding plate outlet and the rail. (It is not necessary to remove the bit guide.)

◆ Adjustment of the passage plate

Check the height of the passage plate.

- Ensure that the passage plate is adjusted at a height where the used screw can manage to pass.
- If the passage plate is too low, the screw cannot pass, and if too high, the screw easily gets caught.
- If adjustment is necessary, adjust it by loosening the passage plate attaching screw.

⚠ **Caution:** Slide the half blanking at both sides of the passage plate up and down the guide.

◆ Adjustment of the rail

Check the physical relationship of the stopper and sensor.

- ensure that the rail is fixed so that "A" portion of the stopper is 0 mm to 0.5 mm ahead of the sensor optical axis.
- If adjustment is necessary, adjust the location by loosening the rail attaching screw.

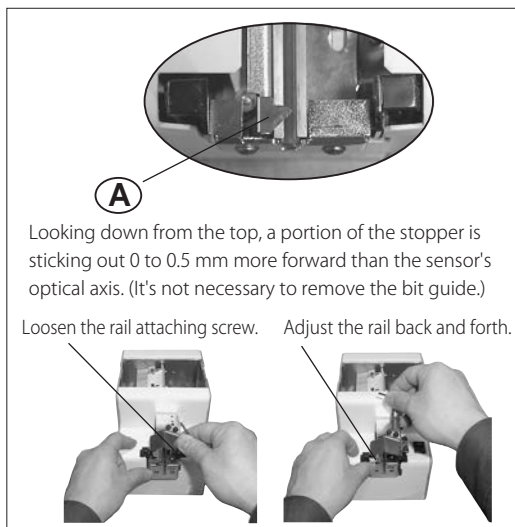
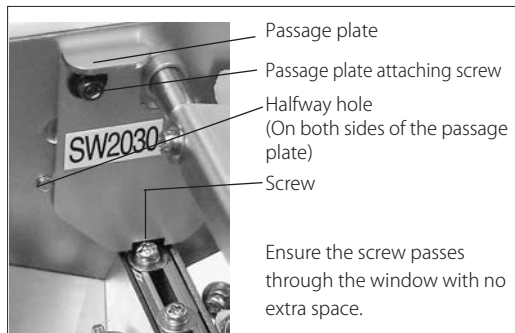

◆ Check/adjustment of the bit guide

Check the position of the bit guide.

- Adjust the bit guide to a position where a user can easily take screws.

Actually pick up screws a few times to adjust it.

Adjust it by loosening the attaching screws.

- ⚠ **Caution:** The rail is adjusted according to the physical relationship with the sensor as on the preceding page, so basically the rail is not adjusted here.

◆ Adjustment of the left and right guide pieces

Please check and adjust position of the guide piece as necessary.

The bit guide is originally set at approximately 3mm at the front opening, and shall be adjusted as needed by the user.

- Unfasten the front fixing screws, insert driver-bit to be used and adjust the slit opening, so that the bit can move freely.
- After the adjustment, try to pick up a screw and check its working condition before turning on the power.

◆ Check/adjustment of rail vibration

Transfer speeds of screws differ according to screw type.

This machine can change rail amplitude and adjust the transfer speed.

- To adjust amplitude, loosen an amplitude fixing screw at the rear of this machine and turn the amplitude adjusting screw at the bottom of the machine.
- To adjust amplitude, loosen an amplitude fixing screw at the rear of this machine and turn the amplitude adjusting screw at the bottom of the machine.

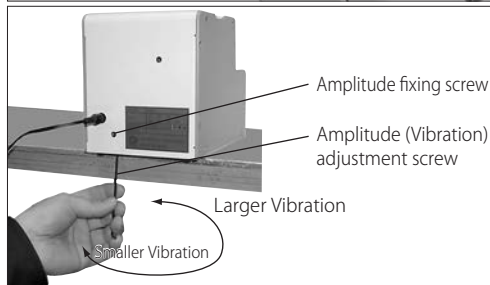
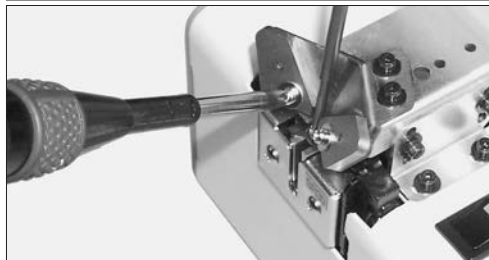
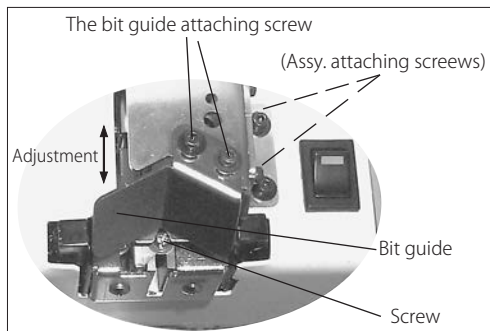

Viewing it from the bottom, if turned clockwise, the amplitude becomes larger, and if turned counterclockwise, the amplitude becomes smaller.

- If you make the amplitude too large in order to speed up the transfer, it may become difficult to pull up screws. So, adjust it to appropriate amplitude for the type of screw being used.
- After adjustment is completed, be sure to tighten the amplitude fixing screw on the rear of the machine.

◆ Adjustment of the tilting bolts

As the original setting, the automatic screw feeder shall be horizontal when set on a surface.

Depending on specific type of screw applied, there may be cases that the screws cannot move smoothly. At such instance, please check the "Adjustment of the rail" section listed in this operation booklet, or adjust tilting angle of the machine as necessary.

- The tilting bolts are located on bottom rear end of the machine.
- When these bolts are used, they shall be set at the same height and angle on both sides.
- Since the bolts do not have stoppers equipped inside, please be careful not to detach them from the machine body.
- After the adjustment, please verify if screw delivery functions properly before application.

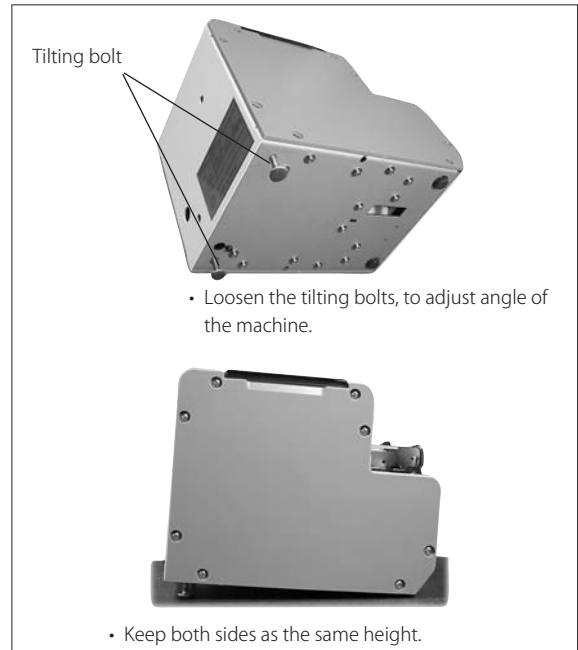

◆ Check of the sensor's optical axis

If there is no screw at the stopper section, this machine continues operation, and if there are screws, it stops after a certain period of time has passed. This machine has the level of the screw/no screw sensor adjusted by the reference rail on shipment. In reality, however, a level adjustment of the sensor may become necessary when using thin-head screws or due to occurrence of the variation on rail replacement. Then, follow the directions (1) and (2) for the adjustment.

- (1)
 - Loose the sensor attaching screw on the side lit up as much as it moves by picking up the sensor holder with fingers, and turn on the power switch.
 - Place a screw on the rail within the sensor range.
 - Hold the rail end lightly with fingers as much as it doesn't vibrate so that screws doesn't pass through.
 - When the sensor holder is moved up and down, there is a position the sensor of the receiving light side defects a screw head and stops the vibration. Tight the sensor attaching screw at this position.
 - Confirm whether it really works or not. See if a screw passes through and the sensor detects if and stops.
- (2)
 - Remove the machine body rear cover, and measure the voltage level. Adjust the IC4050 7th-pin voltage level. The ground, when measuring it, is the body's metal part.
 - Adjustment is not necessary if the voltage level is within 0.25 to 1.5V when a rail is and if there is no screw at the stopper section.
 - When adjustment is necessary, loosen the sensor attaching screw on the side. Adjust the voltage level by moving it up and down. (It is easier to make an adjustment if connector of the main motor is removed.)
 - After the adjustment, throw in the screws and run it practically in order to check the operation.

Note: When no loaded screws are: 0.25 V to 1.5 V
When loaded screws are: 3.5 V or more.

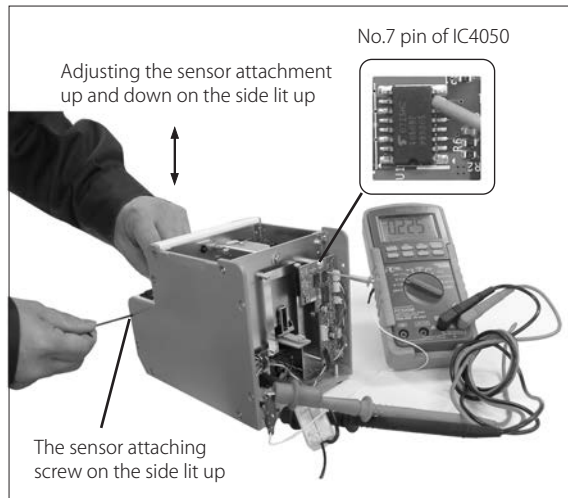

◆ Adjustment and Check of the timer

The speed of screw delivery depends on the actual kind of screw. By adjusting the timer of the machine the screws are picked up smoothly.

- If a screw is picked up on the stopper and the screw coming next is not picked up for a certain amount of time, the unit stops the operation. Then if you pick up the screw, it starts operating again. You can change the time by adjusting the timer within 1 to 6 seconds.
- Time changes after adjusting the times setting volume on the rear of the machine as shown on the right. Viewing the unit from the back, if it's turned clockwise, the time becomes longer, and if it's turned counterclockwise, the time becomes shorter.
- Do not use excessive force while making an adjustment. Turn it only as much as the possible rotating range allows.

⚠ Caution: Use the screwdriver provided with the machine. Using other screwdrivers may damage circuit components.

◆ The operation check of the overload protection circuit

For overload detection and check of protection circuits: Try to force the movement of the scooping block to stop, to check the operation of overload detection and overload protection circuits. If you force the movement of the scooping block to stop for about 4.5 seconds or less, the main motor stops after repeating rotations of reverse -> forward -> reverse -> .

To cancel the above operational check, turn off and then turn on the power switch again.

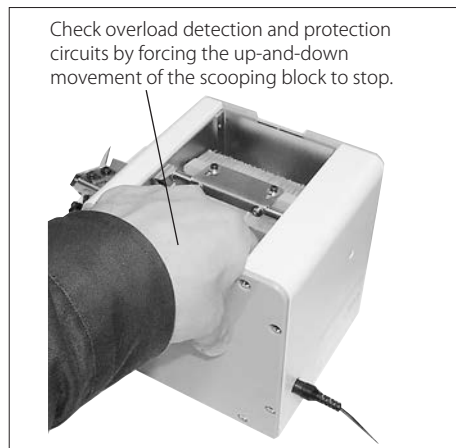
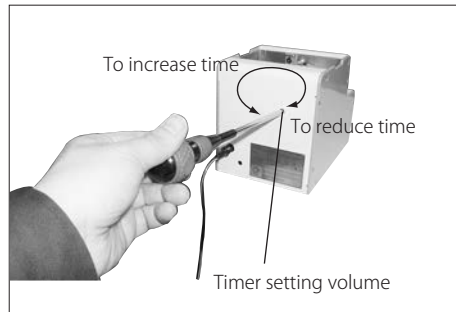

5) OPERATING INSTRUCTIONS

◆ Supplying screws (Refer to P. 6)

- Set the [scooping block] to the lowest possible position. Remove the top cover of the [scooping chamber]. Throw in screws up to a position of 2 mm to 3 mm below the rail groove top face.
- In this condition, ensure that the front inclined-face of the ramp is not hidden by the screws.

 **Caution:** An excessive quantity of screws thrown in may cause a machine malfunction.

◆ Switch-on

- Plug the provided AC adapter into a wall outlet and into the machine.
- Turn on the power switch. The power switch lamp will light up.
- The up-and-down movement of the scooping block and back-and-forth movement of the rail will activate.
- Subsequently, screws are successively sent to the outlet direction. Unless you pick up the screws in the stopper section, the sensor senses it and the machine stops operation.
- If you pick up the screws in the stopper section, the sensor senses it and the machine resumes operation.

◆ Picking up screws

- When picking screws up, use a bit that fits the screw diameter and groove width of the holding plate.
- Make a motor-driven driver's bit upright, put it down to the vertical direction along the V groove of the bit guide while turning it, and pull it out toward yourself when cross recess on the screw head.

 **Caution:** Do not exert any excessive force to the rail at this time. It may cause the machine to malfunction.

◆ Timer settings (Refer to P. 13)

- If you pick up screws of the stopper section and then do not pull up the next screws for a certain period of time, the machine stops. Operation will resume again after you pick up screws.
- The time until the machine stops is adjustable within 1 to 6 seconds. Adjust it according to the procedure in the diagram on the right.

 **Caution:** Always unplug the AC adapter from the wall outlet before making any adjustments to avoid injury.

6) REPLACEMENT OF CONSUMABLE PARTS

Replacement of brushes

- If the tip of the brush wears out and does not wipe off a screw from an abnormal position, replace it with a new brush.
- Turn the machine's power switch on and off and position the brush as in the diagram on the right. (Position it so that the Brush assembly mounting screws can be easily removed.)
- After reassembly, ensure that the brush and the passage plate do not clash when the Brush assembly moves. The gap is ideally "0" .
- Refer to P. 7, "Check/adjustment of the brush" for mounting adjustments.

Part number of brush assembly:

- HS3-02053

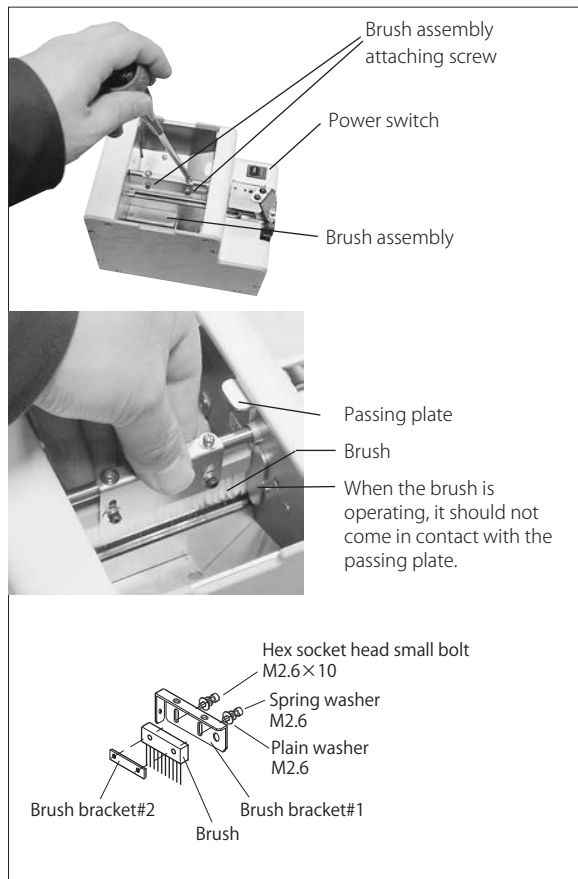

Replacement of the bit guide unit

Replace the holding plate when there is difficulty in using it, such as after excessive wear.

When replacing the holding plate, remove the bit guide section off the body to prevent a mounting screw from falling inside the body.

- As in the diagram on the right, remove the bit guide section and replace the holding plate.
- Refer to P. 8, "Check/adjustment of the holding plate" for mounting adjustments.

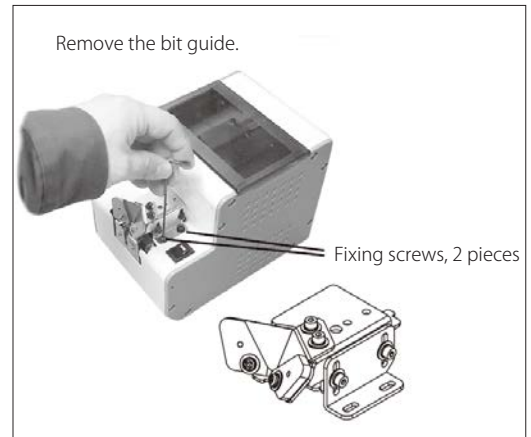

Replacement of the bit guide assembly

Replace the bit guide when there is difficulty in using it, such as after excessive wear.

- As in the diagram on the right, remove the mounting screws and replace it.
- Refer to P. 10, "Check/adjustment of the bit guide" for mounting adjustments.

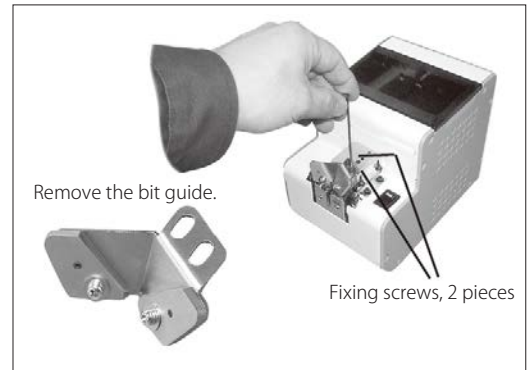

◆ Replacement of the stopper

Replace the stopper when there is difficulty in using it, such as after excessive wear.

- As in the diagram on the right, loosen the rail fixing screws and pull out the rail from the body.
- The stopper can be changed as in the diagram on the right.
- There are three types of stoppers.
- Be careful to correctly match the new stopper to the nominal diameter being used. Determine the type of stopper by examining the hole of the mounting section.

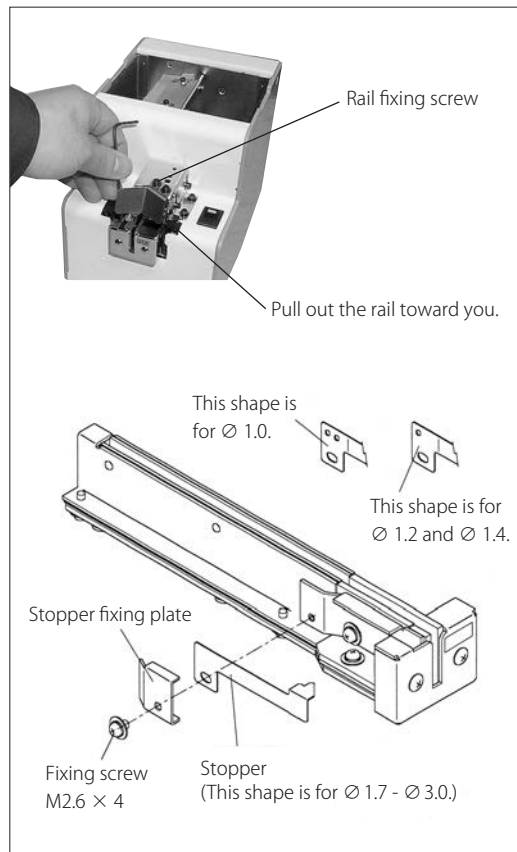

Replacement of the main motor unit

Replace the motor after it is damaged.

- Remove the cover from the body. (During removal, as in the diagram on the right, the cover mounting screws should be removed together with the front cover, leaving the four screws of the rear in place.)
- Remove the motor trunk connector.
- Remove the motor mounting screws on the motor's bottom face.
- Pull out the motor section from the rear of the body. (To facilitate removal, insert a hexagonal wrench into the long hole of the body base and push the motor mounting bracket backward.)
- Be careful not to break motor wires by using overly excessive force.

⚠ Caution: Unplug the AC adapter from the wall outlet before disassembly of the motor section.

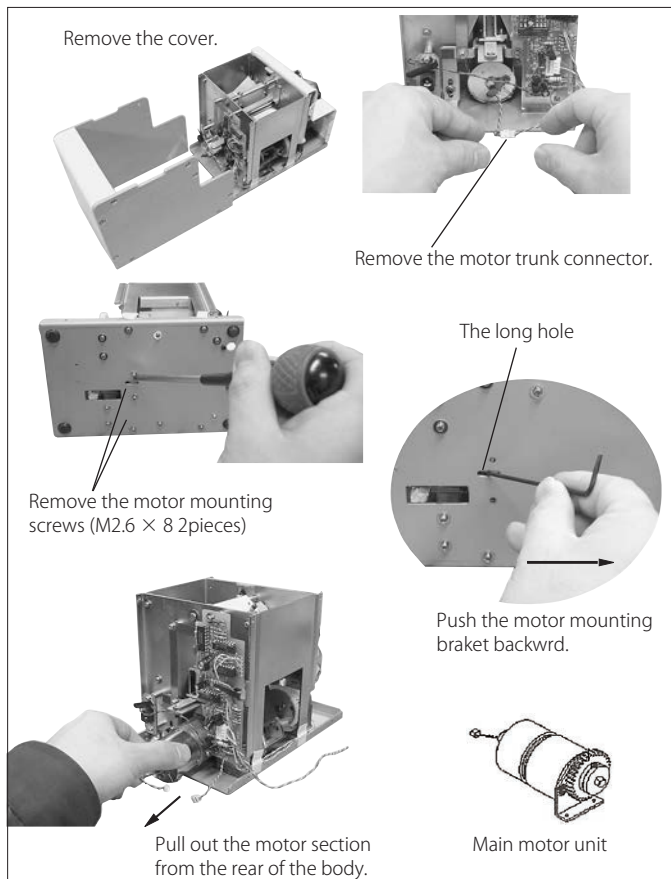

Movement timing when replacing a motor

- To time a movement of the [scooping block] and that of a brush, the gears must be in mesh.
- If only the motor section is removed from the body, the movements can be timed by reassembling the motor section according to the timing in the diagram on the right.
- If it is difficult to mesh the driving gear of the motor section with the right and left trailing gears. Assembly can be made easier by loosening the mounting of the right driving shaft bracket (see the diagram on the right). Be sure to refasten the loosened screws after mounting the motor section.
- After mounting, start the motor and check the movement timing. (The right and left [scooping blocks] must move up and down almost simultaneously.)
- After checking the movement, refer to the wiring diagram and properly position the wiring. (Avoid wires being caught when mounting the cover and be careful not to break motor wires by using overly excessive force.)

⚠ Caution: Unplug the AC adapter from the wall outlet before disassembly of the motor section.

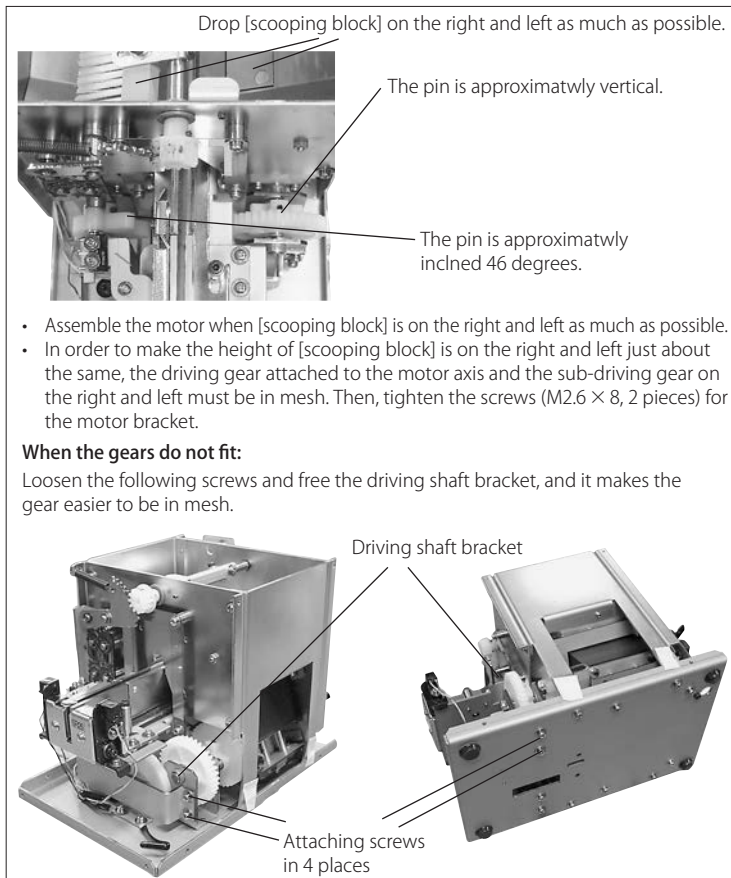

7) EXTERNAL OUTPUT SIGNALS

This machine can take out the screw extraction signal. Please use it for connection with general purpose counter etc. Since the signal line is stored inside, when using it please remove the back cover and pull out the signal line from the grommet.

[Function]: When picked screw up: signal high (ON) approx. 0.2sec

Incoming current: shall be limited to less than 100mA

**CAUTION: Additional resistor is required on external circuit for regulating current **

[Capacity]: Max DC current: 100mA

External supply voltage: 5 - 24 V DC (Max: 27 V DC)

[Caution]: Please keep the length of output signal wire less than 3m.

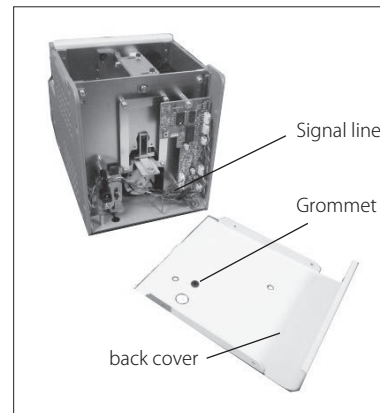

* The purple wire functions as signal output high (Collector end), with the gray wire as common (Emitter end)

Purple line--->Signal line (OFF when no screw is present)

(On when a screw is present)

Gray line --->Common line

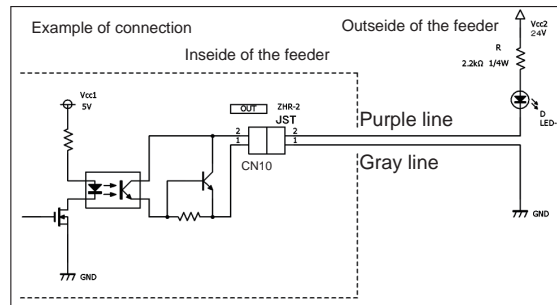

8) TROUBLESHOOTING

 **Caution:** For safety, always unplug the AC adapter from the wall outlet before making any adjustments.

Trouble	Cause	Corrective measures
8-1 The machine does not operate though the power switch is turned ON.	<ul style="list-style-type: none">• Power is not supplied.• The machine has not unloaded screws from the pick up site for a certain amount of time.• Too many screws were loaded into the scooping chamber.• A foreign object (for example: a screw) intruded into the main body.• The AC adapter is faulty.	<ul style="list-style-type: none">• Check the connection of the power supply of the AC power adapter.• Take out the screw from the pick up site.• Adjust the timer setting knob.• Reduce the quantity of screws in the scooping chamber to a proper load level.• Remove the foreign object. • Consult our service section.

Trouble	Cause	Corrective measures
<p>8-2 Screws do no flow.</p>	<ul style="list-style-type: none"> • Screws with a larger diameter than the specified rail size were loaded or screws with a different diameter were mixed in together. • Insufficient quantity of screws are in the scooping chamber. • Screws in an abnormal position in the passing plate cannot be swept away with brush. • The axis of the screw thread entered the passing plate. • A screw has stopped in an abnormal position while moving on the rail. • The rail does not vibrate. (For example, a screw is obstructing the clearance in scooping chamber.) 	<ul style="list-style-type: none"> • Use screws with the specified nominal diameter. • Remove the screws with the odd nominal diameter. • Add a proper quantity of screws into the scooping chamber. • Adjust the brush. Adjust the passing plate. If a proper amount of screws are loaded into the scooping chamber, the status may be improved. Use the optional brush. (stiffer bristles) • Remove the abnormal screw and check and adjust the passing plate. • Remove the screw in the abnormal position. Take care not to damage the rail groove. Move the bit guide bracket upward to remove the screw. After, adjust the position of the bit guide bracket in relation to height and direction. • Remove the screw that is obstructing the clearance. • Check the vibration adjustment. If no screw is obstructing the clearance, consult our service section.
<p>8-3 A screw has fallen in to the rail groove.</p>	<ul style="list-style-type: none"> • Screws with a smaller diameter than the specified rail size were located. 	<ul style="list-style-type: none"> • Use screws with the specified nominal diameter and length.

Trouble	Cause	Corrective measures
<p>8-3 A screw has fallen in to the rail groove.</p>	<ul style="list-style-type: none"> • Screws with a total length shorter than the rail groove width cannot be loaded. 	<ul style="list-style-type: none"> • No corrective measure is available. Consult our service section.
<p>8-4 The flow on the screw rail is improper</p>	<ul style="list-style-type: none"> • The clearance between the bit guide bracket and the head of the loaded screw is narrow. • Screws with a spring washer having one increment smaller than the specified nominal rail size were loaded. • The rail is oily or dirty. • The rail does not vibrate. (A screw is caught in the clearance.) • The motor is worn. 	<ul style="list-style-type: none"> • Adjust the height of the bit guide bracket. Adjust the vibration. If, after following the instructions written above, the machine still does not function properly, consult our service section. • Clean the rail. • Remove the screws caught in the clearance. If there is no screw that is caught, consult our service section. • Adjust the vibration. • Replace the motor.
<p>8-5 Screws tend to pass through the passing plate in an abnormal position.</p> <p>To axis of the screw thread tends to enter the passing plate.</p>	<ul style="list-style-type: none"> • The passing plate is not adjusted properly. • Too many screws are in the scooping chamber. 	<ul style="list-style-type: none"> • Adjust the passing place. • Reduce the quantity of screws to a proper level.

Trouble	Cause	Corrective measures
<p>8-6 No screw comes to the pick up site.</p>	<ul style="list-style-type: none"> • Screws are stopped while still on the rail. • Screws cannot be transferred smoothly from the rail to the escaper. 	<ul style="list-style-type: none"> • Adjust the height of the bit guide bracket. • Adjust the distance between the end of the rail and the escaper as well as the height of the escaper in relation to the rail.
<p>8-7 The machine stops its operation suddenly.</p>	<ul style="list-style-type: none"> • The overload protective circuit was activated. • Too many screws are in the scooping chamber. • A screw is caught in the clearance. • A screw, at the pick up site, could not be picked up for an amount of time. 	<ul style="list-style-type: none"> • Turn the machine OFF and then ON again. • Remove the cause of overload. • Remove screws to a proper level. • When the machine stops, even if the screws are at a proper level, consult our service section. • Remove the screw that is caught. • Remove the screw.
<p>8-8 The scooping operation does not stop though screws are at the pick up site.</p>	<ul style="list-style-type: none"> • The timer knob is not properly adjusted. 	<ul style="list-style-type: none"> • Readjust the timer knob.
<p>8-9 The escaper operation does not stop though screws are at the pick up site.</p>	<ul style="list-style-type: none"> • The sensor does not detect a screw. 	<ul style="list-style-type: none"> • Readjust the voltage of the sensor.

Trouble	Cause	Corrective measures
8-10 A screw has fallen into the machine.		<ul style="list-style-type: none"> • Apply grease to the transport section. • Recommended grease: BR2 Plus, Dow Corning Asia Co. Ltd.
8-11 The noise of the machine has increased.	<ul style="list-style-type: none"> • There is insufficient grease. 	<ul style="list-style-type: none"> • Apply grease to the transport section. • Recommended grease: BR2 Plus, Dow Corning Asia Co. Ltd.
8-12 The escaper does not rotate when no screws are present, although the indicator light is on.	<ul style="list-style-type: none"> • Undesired objects blocking front screw sensor. • Adjustment of the front screw sensor is unsuitable. 	<ul style="list-style-type: none"> • Make sure there are no debris or other objects present in the sensor brackets. • If the escaper or stopper is damaged or worn-off, parts replacement is recommended. • Adjustment on front screw sensor as shown on P. 23.
8-13 The escaper rotates in the wrong direction.	<ul style="list-style-type: none"> • When the escaper is operating, some alien object is preventing the escaper from rotating smoothly. • Escaper and the escaper guide do not fit together. 	<ul style="list-style-type: none"> • Please check if the bit-guide and its mounting bracket are both positioned correctly so that sensors are not interfered or blocked, and that the screw can move freely. • If the escaper or escaper guide is damaged or worn off, replacement is recommended.
8-14 The escaper continues to rotate in the wrong direction.	<ul style="list-style-type: none"> • The origin sensor may be improperly adjusted. 	<ul style="list-style-type: none"> • Please contact your dealer or our service section.

9) SPECIFICATIONS

Power (AC adapter)	Input: AC100-240 V 50/60 Hz
	Output: DC 15 V 1 A
Dimensions	123 (W) × 181 (D) × 145 (H) mm
Weight	Approx. 3kg (including rail)
Screw capacity	80cc
Following accessories	CD-ROM, 1 AC adapter, 1 piece Hexagonal wrench, 1 piece Screwdriver, 1 piece Gauge plate, 1 piece Ground wire 1 piece

Notes:

- Check if the axis diameter of the loaded screw corresponds with the below rail groove width.
- With the range of screw size and lengths below, there may be instances if unique screw shape or structure not compatible with the screw feeder unit.
- In the main body type, the main body model can be changed.
- To change the nominal diameter of loaded screw, replace it with a part that is mentioned in the next page table.
- The rail and passing plate are separately available for replacement.
- The design, performance and specifications are subject to change without prior notice for the sake of improvement.

Screw feeder model	Reference table of the specified screws					Shape of screw head						
	Screw size	Screw shaft diameter (∅)	Screw head diameter (∅)	Screw head thickness (mm)	Screw shaft length (mm)	No.0 pan head	Pan head	Pan head			Bind	Counter sunk head
								Sems	Double sems	Washer head		
HSIII-10	M1.0	0.9 - 0.95	1.8 - 4.5	0.35 - 1.0	1.6 ~ 10	○	—	—	—	—	—	—
HSIII-12	M1.2	1.1 - 1.15	1.8 - 4.5	0.35 - 1.0	1.9 ~ 10	○	—	—	—	—	—	—
HSIII-14	M1.4	1.3 - 1.4	2.0 - 4.5	0.35 - 1.0	2.2 ~ 10	○	—	—	—	—	—	—
HSIII-17	M1.7	1.6 - 1.7	2.5 - 4.5	0.35 - 1.0	2.7 ~ 10	○	—	—	—	—	—	—
HSIII-20	M2.0	1.9 - 2.1	3.0 - 6.0	0.35 - 4.5	3.2 ~ 20	—	○	○	○	○	○	○
HSIII-23	M2.3	2.2 - 2.4	3.3 - 6.0	0.35 - 4.5	3.7 ~ 20	—	○	○	○	○	○	○
HSIII-26	M2.6	2.5 - 2.7	3.6 - 6.0	0.35 - 4.5	4.2 ~ 20	—	○	○	○	○	○	○
HSIII-30	M3.0	2.9 - 3.2	4.0 - 6.0	0.35 - 4.5	4.8 ~ 20	—	○	○	○	○	○	○

* Compatible with washer diameter up to 9 mm, thickness 0.35 to 1.0mm.

● SPECIFICATIONS

Screw feeder model	Screw size	Rail model No.	Passing plate model No.	Stopper model No.	
HSIII-10	M1.0	HS-SR10	HS3-02052-1	HS3-05113	
HSIII-12	M1.2	HS-SR12		HS3-05114	
HSIII-14	M1.4	HS-SR14		HS3-02052-2	HS3-05115
HSIII-17	M1.7	HS-SR17			
HSIII-20	M2.0	HS-SR20			
HSIII-23	M2.3	HS-SR23			
HSIII-26	M2.6	HS-SR26			
HSIII-30	M3.0	HS-SR30			

- In the Exchange kit ordered, Rail assembly and Passing plate are included.

● Replacement parts

- Rail

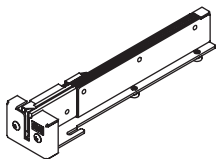

- Passing plate



- Brush assembly
HS3-02053

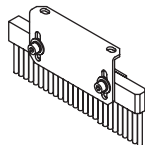

- Stopper

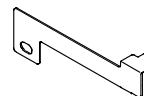

- Main motor unit
HS3-03056

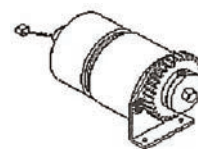

- Bit guide B assembly
HS3-06002

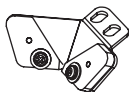

- Bit guide unit
HS3-06003

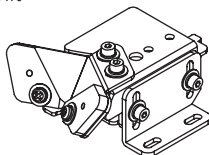

10) EXTERNAL DIMENSIONS

The dimensions in the manuals are for reference only do not use it for your jig.
The specifications are subject to change without notice.

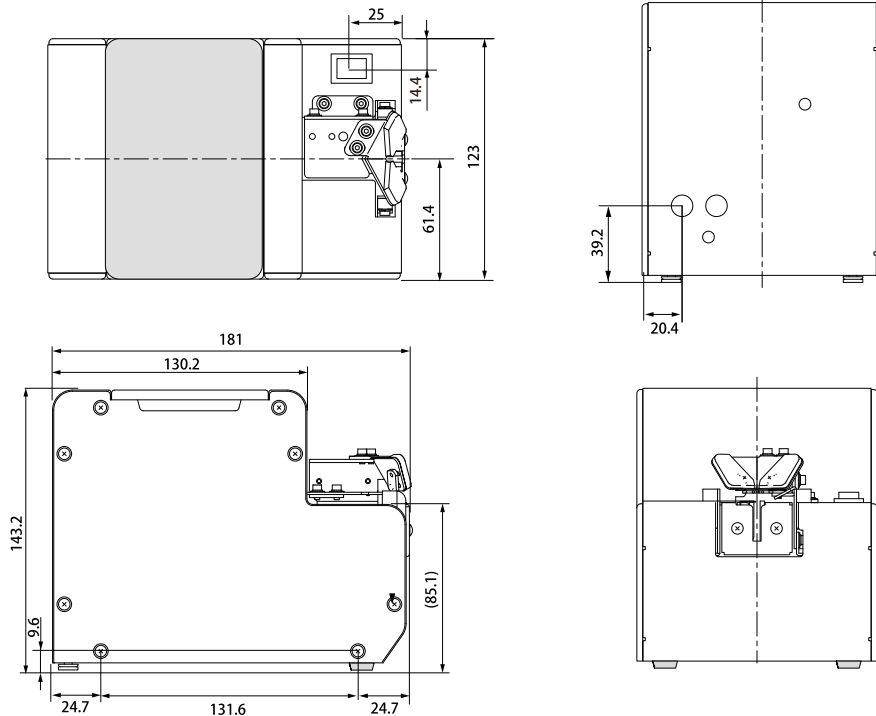

unit: mm

11) THE FOLLOWING TABLE IS FOR CHINA RoHS2

If you are asked by China Customs, please show this table to them.

有害物质名称及含量标识格式						
产品中有害物质的名称及含量						
部件名称	有害物质					
	铅(Pb)	汞(Hg)	镉(Cd)	六价铬 (CR(VI))	多溴联苯 (PBB)	多溴二苯醚 (PBDE)
驱动齿轮, 轴心部件	×	○	○	○	○	○
铆钉	×	○	○	○	○	○
六角铜柱	×	○	○	○	○	○
电路板元件	×	○	○	○	○	○
连接器	×	○	○	○	○	○
-						
-						
-						

本表格依据 SJ/T 11364 的规定编制。
 ○ : 表示该有害物质在该部件所有均质材料中的含量均在 GB/T 26572 规定的限量要求以下。
 × : 表示该有害物质至少在该部件的某一均质材料中的含量超出 GB/T 26572 规定的限量要求。

In addition, the China RoHS marks also is required at the product and product box.

At the product, you can find it at the bottom and it is marked on the product box.

If you cannot find the mark, please ask your distributor.

In case of emergency, please cut the mark below and stick at the bottom of product and on the product box.

China RoHS mark

